

User Manual of Information System



CS OTE External Interface Message formats for DM, IDA, Sol, RRD, FS, CDS

This document and its content are confidential. It is forbidden to reproduce the document or its parts, to show it to third parties or to use it for any other purposes than it was provided for without prior written agreement by OTE, a.s.

Date	Version	Description of changes
14.12.2023	A	Creation of document
05.02.2024	B	Correction of return codes in the Reason.code attributes for the DM and IDA
23.02.2024	C	Revision of profile roles related to DM settlement in section 7.3.2. Adding missing Reference element into the ISOTEDATA content description.
13.03.2024	5.7	FS scenarios updated. Added CDSDATA structure, removed unused reports and fixed message codes. Document version numbering change to match versioning in cs locales.
07.05.2024	5.8	ISOTEDATA corrections, attribute TimeData/datetime-type (fixing values meaning) and element Comment (length increase from 30 to 100 characters). Correction of a precedence of RD status request input paranaters variants.
19.06.2024	5.9	ISOTEDATA a RESPONSE – straighten specification of attributes reference/id, external-id, parent-external-id. Acknowledgement_MarketDocument – adding additional reason code A02.
14.08.2024	6.0	Attribute */value extended to 5 decimal places.
10.09.2024	6.1	Message SoM and SoI RESPONSE extended with new attributes.
1.12.2024	6.2	Modified profiles in the section Identification of SoM and SoI profiles
1.4.2025	6.3	Extension of the Marginal Prices scenario to include the resulting volume data on DT/IDA (messages with message-code = 946 and 949)
8.12.2025	6.4	Addition messages ISOTEDATA DM and IDA
10.04.2026	6.5	New error message for the DM area
25.05.2026	6.6	DM – Implementation of cyclical blocks

Content

1. Reference documents.....	8
2. Abbreviations.....	9
3. Communication Messages - General Information.....	11
3.1. OTE message formats by area DM, IDA and Settlement.....	11
3.1.1. Standard OTE message header format.....	11
3.1.2. Date and time values in messages.....	12
3.2. CIM message formats for DM, IDA and RRD areas.....	13
4. Day-ahead Market.....	14
4.1. DM Communication Scenarios.....	14
4.1.1. Creation/Modification of DM Order.....	14
4.1.2. Cancelation of DM Order.....	15
4.1.3. Checking Status of DM Order.....	16
4.1.4. Data Request - DM Marginal Prices and Volume.....	17
4.1.5. Data request - DM Capacity Data.....	18
4.2. Content of DM Data Messages.....	19
4.2.1. ISOTEDATA.....	19
4.2.2. RESPONSE.....	25
4.2.3. ISOTEREQ.....	31
4.2.4. StatusRequest_MarketDocument.....	32
4.2.5. Capacity_OTEMarketDocument.....	33
4.2.6. Acknowledgement_MarketDocument.....	35
5. Intraday Auctions (IDA).....	38
5.1. IDA Communication Scenarios.....	38
5.1.1. Creation/Modification of IDA Order.....	38
5.1.2. Cancelation of IDA Order.....	39
5.1.3. Checking Status of IDA Order.....	40
5.1.4. Data Request - IDA Marginal Prices.....	41
5.1.5. Data Request - IDA Capacity Data.....	42
5.2. Content of IDA Data Messages.....	43
5.2.1. ISOTEDATA.....	43
5.2.2. RESPONSE.....	49
5.2.3. ISOTEREQ.....	54
5.2.4. StatusRequest_MarketDocument.....	55
5.2.5. Capacity_OTEMarketDocument.....	56
5.2.6. Acknowledgement_MarketDocument.....	58
6. Registration of Realization Diagrams (RRD).....	61
6.1. RRD Communication Scenarios.....	61
6.1.1. RD Entry.....	61
6.1.2. RD Status Request.....	62
6.1.3. RD Matching Outcome.....	63
6.1.4. RD Mass Messages.....	64
6.2. Content of RRD Data Messages.....	64
6.2.1. Schedule_MarketDocument.....	64

6.2.2.	Acknowledgement_MarketDocument.....	67
6.2.3.	StatusRequest_MarketDocument.....	69
6.2.4.	AnomalyReport_MarketDocument.....	72
6.2.5.	Confirmation_MarketDocument.....	75
6.2.6.	Return codes in the Reason element for the RRD area.....	78
6.2.7.	RESPONSE.....	81
7.	Settlement of Markets (SoM) and Imbalances (SoI)	83
7.1.	<i>SoM and SoI Communication Scenarios.....</i>	83
7.1.1.	Data Request - Final Plan.....	83
7.1.2.	Data Request - Breakdown of Settlement Results.....	86
7.1.3.	Data Request - Settlement Results (Electricity).....	87
7.1.4.	Data Request - Statistical data of imbalance settlement.....	88
7.1.5.	Data Request - Settlement Results (Gas).....	89
7.2.	<i>Content of SoM and SoI data messages.....</i>	90
7.2.1.	ISOTEREQ.....	91
7.2.2.	RESPONSE.....	92
7.2.3.	ISOTEDATA.....	94
7.3.	<i>Identification of SoM and SoI profiles.....</i>	97
7.3.1.	Final plan.....	97
7.3.2.	Breakdown of Settlement results and Settlement results (electricity).....	98
7.3.3.	Statistical data of settlement of imbalances.....	107
7.3.4.	Settlement results (gas).....	109
8.	FS.....	111
8.1.	<i>Communication scenarios.....</i>	111
8.2.	<i>Content of data messages.....</i>	112
8.2.1.	SFVOTREQ.....	112
8.2.2.	SFVOTGASREQ.....	112
8.2.3.	SFVOTSETTINGS.....	112
8.2.4.	CDSDATA.....	113
8.2.5.	RESPONSE.....	113
8.2.6.	GASRESPONSE.....	113
8.2.7.	Data structures.....	113
9.	CDS.....	114
9.1.	<i>CDSDATA message.....</i>	114
9.1.1.	Description of changes in the existing CDSDATA format.....	114
9.1.2.	Impact of changes to code lists.....	115
9.1.3.	Documentation of the CDSDATA report in its entirety.....	117

List of Images

Figure 1 - Communication scenario - Creation/Modification of orders on DM.....	15
Figure 2 - Communication scenario - Cancellation of DM Order.....	16
Figure 3 - Communication scenario - Checking status of DM Order	17
Figure 4 - Communication Scenario - Data Request - DM Marginal Prices.....	18
Figure 5 - Communication scenario - Data request - DM Capacity Data	19
Figure 6 - Communication scenario - Creation/Modification of IDA Order.....	39
Figure 7 - Communication scenario - Cancellation of IDA Order	40
Figure 8 - Communication scenario - Checking status of IDA Order.....	41
Figure 9 - Communication Scenario - Data Request - IDA Marginal Prices	42
Figure 10 - Communication scenario - Data Request - IDA Capacity Data	43
Figure 11 - Communication scenario - Creating RD.....	62
Figure 12 - Communication scenario - Determining the status of the RD	63
Figure 13 - Communication Scenario - RD Matching Outcome.....	63
Figure 14 - Communication Scenario - RD Mass Messages.....	64
Figure 15 - Communication Scenario - Data Request - Final plan	86
Figure 16 - Communication scenario - Data Request - Breakdown of Settlement Results	87
Figure 17 - Communication scenario - Data Request - Settlement Results (electricity)	88
Figure 18 - Communication scenario - Data Request - Statistical Data of imbalance settlement	89
Figure 19 - Communication scenario - Data Request - Settlement Results (Gas).....	90

List of tables

Table 1 - Standard OTE message header format for DM, IDA and Settlement areas.....	11
Table 2 - Date and time expected values.....	12
Table 3 – Communication methods for DM communication scenarios	14
Table 4 - Content of data messages DM - ISOTEDATA.....	19
Table 5 – List of profiles – DM messages	24
Table 6 - Content of DM - RESPONSE data messages	25
Table 7 - Errors/messages for the DM area - fulfillment of the code, result-code and error-code attributes	26
Table 8 - Mass DM messages	30
Table 9 - Content of DM data messages – ISOTEREQ	31
Table 10 - Inquiry about a specific order:	32
Table 11 - Inquiry for all orders for a specified delivery day:	32
Table 12 - StatusRequest_MarketDocument (v4.1)	32
Table 13 - Capacity_OTEMarketDocument (CIM like Capacity_MarketDocument v8.1)	33
Table 14 - Acknowledgement_MarketDocument (v8.1).....	35
Table 15 - Acknowledgement_MarketDocument (v8.1) – Return codes of the Reason.code, Reason.text attributes for the DM region.....	36
Table 16 – Communication methods for communication scenarios IDA	38
Table 17 - Data message content IDA – ISOTEDATA	43
Table 18 – List of profiles – IDA messages.....	47
Table 19 - Content of IDA - RESPONSE data messages	49
Table 20 - Errors/reports for IDA area - code, result-code and error-code attribute fulfillment	50
Table 21 - Mass IDA messages.....	54
Table 22 - Content of IDA - ISOTEREQ data messages	54
Table 23 - Inquiry about a specific order:	55
Table 24 - Query on all orders for the specified delivery day (and possibly the auction):.....	55
Table 25 - StatusRequest_MarketDocument (v4.1)	55
Table 26 - CapacityDocument_OTEMarketDocument (CIM like CapacityDocument_MarketDocument v8.1) .	56
Table 27 - Acknowledgement_MarketDocument (v8.1).....	59
Table 28 - Acknowledgement_MarketDocument (v8.1) – Return codes of the Reason.code, Reason.text attributes for the IDA area.....	60
Table 29 – Communication methods for RRD communication scenarios	61
Table 30 - Schedule_MarketDocument (v5.2).....	64
Table 31 – Acceptable combinations of values of some items for RD Entry.....	67
Table 32 – Acknowledgement_MarketDocument (v8.1).....	68
Table 33 - StatusRequest_MarketDocument (v4.1)	69
Table 34 – Two variants of the RD query	72
Table 35 - AnomalyReport_MarketDocument (v5.3).....	73
Table 36 - Confirmation_MarketDocument (v5.3)	75
Table 37 - The return codes of the Reason.code, Reason.text attributes for the RRD region	78
Table 38 – RRD RESPONSE	81
Table 39 - Bulk RRD messages	82
Table 40 – Methods of communication for communication scenarios SoM and SoI.....	83
Table 41 - Content of SoM and SoI data messages (electricity) – ISOTEREQ.....	91
Table 42 - Query the current final plan.....	92
Table 43 - Query for a time snapshot of the final plan according to a specific settlement version.....	92
Table 44 - Content of SoM and SoI - RESPONSE data messages.....	92
Table 45 - Errors/reports for the area of SoM and SoI (electricity) - filling in the attribute code, result-code and error-code	93
Table 46 - Mass messages SoM and IS.....	94
Table 47 - Content of SoM and SoI data reports - ISOTEDATA	94
Table 48 - Profile List - Final plan.....	97
Table 49 - Profile list – Breakdown of Settlement results and Settlement results (electricity).....	99
Table 50 - Profile list – Statistical data of settlement of imbalances	108

Table 51 - Profile list – Settlement results (gas)	109
Table 52 - FS reports and their codes for the electricity commodity	111
Table 53 - FS reports and their codes for the gas commodity	111
Table 54 - FS reports and their codes for both commodities	112
Table 55 - SFVOTREQ.....	112
Table 56 - SFVOTSETTINGS.....	112
Table 57 - RESPONSE return codes for FS area	113
Table 58 - Changes in the Data element	114
Table 59 - Changes in the Location element.....	114
Table 60 – Role of Profiles	115
Table 61 – Time period resolution	116
Table 62 – Message codes with value profile	116

1. Reference documents

- [1] D1.4.3_ENG_web_services_interface_15min.docx
- [2] XML Structures Definition (XSD)

2. Abbreviations

AC	Automated communication
AnS	Ancillary Services
AR	Activity Report
AS	Application server
BE	Balancing energy
CDS	Center of Data Services
CR	Confirmation Report
CS OTE	Computer system OTE a.s.
DM	Day-ahead Market
EAN	European Article Number - Unique international general identifier
EIC	Energy Identification Code - Unique international identifier in the energy sector
EMTAS	Modul in subsystem CS OTE (Energy Market Trading and Settlement)
FMS	Final Monthly Settlement
FS	Financial Security
IDA	Intra Day Auction
IME	Intraday Market with Electricity
IMG	Intraday Market with Gas
IMW	Integration layer CS OTE
IS OTE	OTE information system
LP	Load Profiles
MI	Monthly Imbalance
MP	Market Participant
MS	Monthly Settlement

OTE	Company OTE, Inc.
PXE	Power Exchange Central Europe, a.s.
RD	Realization diagram/Time series (series with a commodity transmission plan)
RRD	Registration of Realization Diagram
SFVOT	Module to provide financial security and settlement of electricity and gas market participants
SE	State of Emergency
Sol	Settlement of Imbalances
SoM	Settlement of Markets
SS	Balance responsible party (Subject of Settlement)
SSS	Super Subject of Settlement
TSO	Transmission System Operator
UTC	Coordinated Universal Time
XML	Extensible Markup Language

3. Communication Messages - General Information

The purpose of this chapter is to define general information valid for all communication messages of communication scenarios that can be carried out as part of automatic communication, divided according to individual IS OTE agendas.

3.1. OTE message formats by area DM, IDA and Settlement

The following automatic communication message formats are used for entering instructions and data queries within the DM, IDA and Settlement agendas and in the mass message area of said agendas:

- ISOTEDATA
- ISOTEREQ
- RESPONSE

A large number of XML structures with the prefix SFVOT in the root element are used for the area of financial security. All of them serve as the output of various reports generated by the FS module and have a uniform header like the other structures mentioned above.

3.1.1. Standard OTE message header format

The chapter describes the meaning of the attributes of the standard header, which is used for all OTE format reports for the markets area. If a specific communication scenario requires specific use of the header attribute, this is also mentioned for individual messages in chapters 4.2 *Content of DM data messages*, 5.2 *Content of IDA data messages*, 7.2 *Content of MS and IS data messages* or 8.2 *Content of data messages*.

Table 1 - Standard OTE message header format for DM, IDA and Settlement areas

Attribute	Description	Data type or example ¹	Usage in messages ²
Standard Message Header			
*/xmlns	XML namespace of the message	http://www.ote-cr.cz/schema/market/data	P
*/id	Message identifier. Numeric entry: max. 35 digits.	ote:msg-id 76638	P
*/message-code	Message code identifying the message type. Numeric entry: fixed length of 3 digits.	xsd:string 811	P
*/date-time	Date and time of the message in ISO 8601 format in UTC format (see chapter 3.1.2 Date and time values in messages).	xsd:dateTime 2020-06-18T16:32:03Z	P
*/dtd-version ³	Version designation (used previously as a fallback for later versions).	xsd:string 1	V

¹ Example:

A01	Value example
A05	Constant
{A01; A10}	List of possible constants

² Usage in messages: P = Mandatory item; V = Optional item

³ The dtd-version attribute is defined only in the RESPONSE header. For ISOTEDATA and ISOTEREQ, the attribute in the message header is not defined.

Attribute	Description	Data type or example ¹	Usage in messages ²
*/dtd-release ⁴	Release designation (used previously as a fallback for a later release).	Xsd:string 1	V
*/answer-required ⁵	Response request indication: • 1=Yes • 0=No	xsd:boolean {0; 1}	P
SenderIdentification			
*/id	Sender identification: • EAN code – used in communication scenarios for electricity (numerical entry: fixed length of 13 digits). • EIC code - used in communication scenarios for gas (text item: fixed length 16 characters)	xsd:string EAN: 8591824011607 EIC: 11XJKL-CZ-----1	P
coding-scheme	Coding scheme of sender identification: • 14 – for EAN code (European Article Number) • 15 – for EIC code (Energy Identification Coding Scheme)	xsd:string {14; 15}	P
ReceiverIdentification			
*/id	Receiver identification: • EAN code – used in communication scenarios for electricity (numerical entry: fixed length of 13 digits). • EIC code - used in communication scenarios for gas (text item: fixed with length 16 characters)	xsd:string EAN: 8591824011607 EIC: 11XJKL-CZ-----1	P
*/coding-scheme	Coding scheme of receiver identification: • 14 – for EAN code (European Article Number) • 15 – for EIC code (Energy Identification Coding Scheme)	xsd:string {14; 15}	P

* Message format = ISOTEDATA or RESPONSE or ISOTEREQ

3.1.2. Date and time values in messages

Date and time items are defined as "dateTime" data type. The format of these items in XML messages is expected to be as follows:

- YYYY-MM-DDThh:mm:ssZ (example: 2020-06-18T16:32:03Z)

Table 2 - Date and time expected values

Symbol	Description	Example
YYYY	Year	2020
MM	Month	06
DD	Day	18
T	Date and time separator	T
hh	Hour (00-23 h)	16
mm	Minute (00-59)	32
ss	Second (00-59)	03
Z	UTC time	Z

⁴ The dtd-release attribute is defined only in the RESPONSE header. For ISOTEDATA and ISOTEREQ, the attribute in the message header is not defined.

⁵ The answer-required attribute is defined only in the ISOTEDATA header. For RESPONSE and ISOTEREQ, the attribute in the message header is not defined.

All values are expected in UTC.

3.2. CIM message formats for DM,IDA and RRD areas

The automatic communication message formats below are used for capacity data queries within the DM and IDA agendas:

- StatusRequest_MarketDocument v4.1
- Capacity_OTEMarketDocument v8.1⁶
- Acknowledgement_MarketDocument v8.1

The automated communication message formats below are used for the communication scenarios within the RRD agenda:

- StatusRequest_MarketDocument v4.1
- Acknowledgement_MarketDocument v8.1
- Schedule_MarketDocument v5.2
- Confirmation_MarketDocument v5.3
- AnomalyReport_MarketDocument v5.2

⁶This is a modified CIM Capacity_MarketDocument_v8.1 template, as CIM does not define a standard for FB data of capacities and other SDAC specifics

4. Day-ahead Market

4.1. DM Communication Scenarios

The schematic representation of communication scenarios does not take into consideration specific technicalities related to the relevant web service and does not address specific differences in Server-Server and Client-Server communication, for the sake of simplicity it only shows in which message format the MP transmits the given request and which message format is provided as a response.

The communication methods for individual DM communication scenarios are summarized in the following table, a detailed description of the mentioned communication methods and relevant web services is given in [1].

Table 3 – Communication methods for DM communication scenarios

Communication scenario	Communication method
Creation/Modification of DM Order (chapter 4.1.1)	Asynchronous communication scenario
Cancelation of DM Order (chapter 4.1.2.)	Asynchronous communication scenario
Checking Status of DM Order (chapter 4.1.3)	Asynchronous communication scenario
Data Request - DM Marginal Prices (chapter 4.1.4)	Asynchronous communication scenario
Data request - DM Capacity Data (chapter 4.1.5)	Asynchronous communication scenario

4.1.1. Creation/Modification of DM Order

The communication scenario enables creation or modification (replacement) of the DM order(s). Within this communication scenario, OTE data formats are used. The meaning of the individual items of the message formats used is defined within the chapter 4.2 *Content of DM Data Messages*.

One creation (or modification) request may contain creation (or modification) of any number of orders. Following messages may be provided back as an outcome of the order creation/modification request:

- RESPONSE containing a result of the order creation/modification request processing, it is always provided
- ISOTEDATA containing a full definition of the created/modified order

One pair of these messages is provided separately for each individual order of the order creation/modification request, and only if the condition of successful formal validation is met. If the formal validation condition is not met, only a negative RESPONSE message is returned for each rejected order. In case the formal validation of a given order is successful, but there is MP’s insufficient financial security indicated for the given order, a negative RESPONSE message is returned for such order with insufficient financial security alongside with ISOTEDATA message comprising full definition of the given order created/modified as invalid.

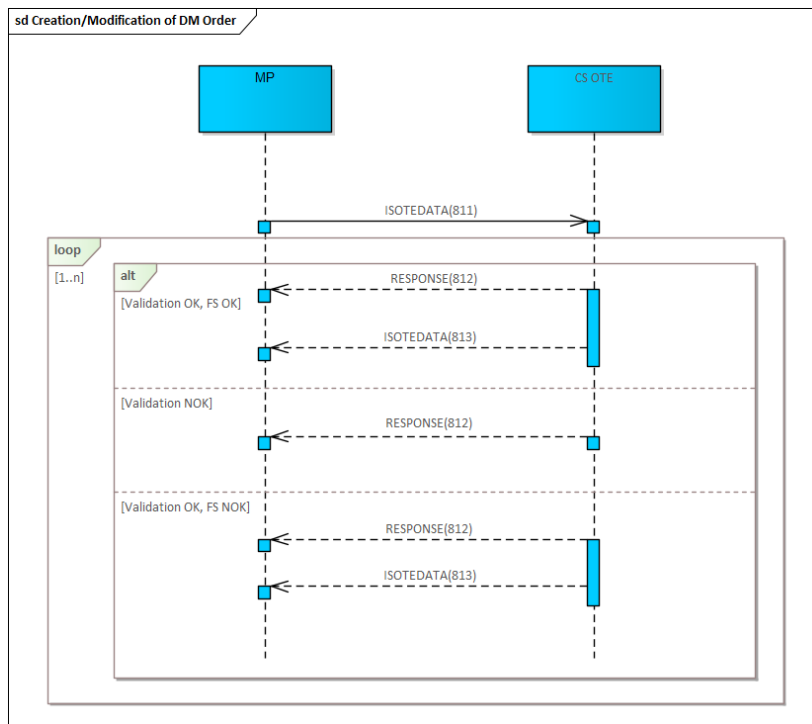

Figure 1 - Communication scenario - Creation/Modification of orders on DM

4.1.2. Cancellation of DM Order

The communication scenario allows cancellation of DM order, or mass cancellation of DM orders. Within this communication scenario, OTE data formats are used. The meaning of the individual items of the message formats used is defined within the chapter 4.2 *Content of DM Data Messages*.

One message may contain a request to cancel any number of orders.

Following messages may be provided back as an outcome of the order(s) cancellation request:

- RESPONSE containing the result of the order cancellation request processing, it is always provided
- ISOTEDATA containing a full definition of the canceled order

One pair of these messages is provided separately for each individual being canceled order, and only if the condition of successful formal validation is met. If the formal validation of the given order is not successful, only a RESPONSE message is returned for such order.

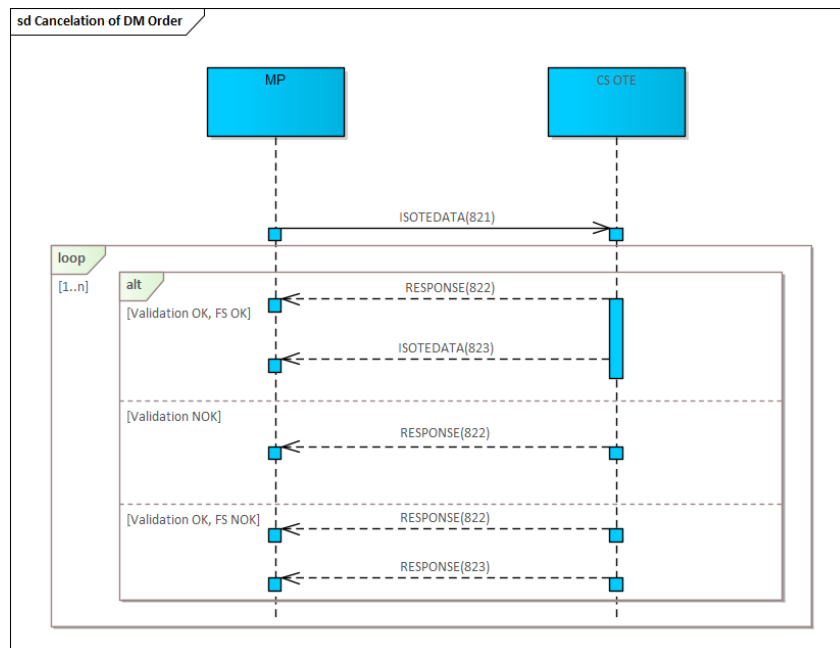

Figure 2 - Communication scenario - Cancellation of DM Order

4.1.3. Checking Status of DM Order

The communication scenario purpose is to find out the status of any specific DM order (in case the request selection criteria refer to specific order id and order version values) or set of DM orders (in case the request selection criteria refer to a specific delivery day).

One message contains exactly one request with specific query criteria to get full order definition data, the result of which can be no order (invalid selection criteria), or just one order (for order id and version specified) or a set of orders (for the required delivery day specified). Within this communication scenario, OTE data formats are used. The meaning of the individual items of the message formats used is defined within the chapter 4.2 *Content of DM Data Messages*.

One pair of following messages may be provided back as an outcome of DM Order status request:

- RESPONSE containing the result of the DM order status request processing, it is always provided
- ISOTEDATA containing a full definition of the being asked DM order, or being asked set of DM orders
 - this message is not provided if no order matches the selection criteria of the request

In case a formal validation of the request is not successful, only a negative RESPONSE message is returned.

Note: The DM order(s) status request with valid selection criteria coming from Power Exchange (PXE) will result into full order definition data comprising:

- either DM order(s) data sourced from the "PXE" system only,
- or DM order(s) data sourced from both "PXE" and "OTE" systems, provided that market participants for which Power Exchange can enter DM orders on behalf of, explicitly allows "OTE" system sourced data to be visible to Power Exchange via the activity "Publishing participant contract for PXE".

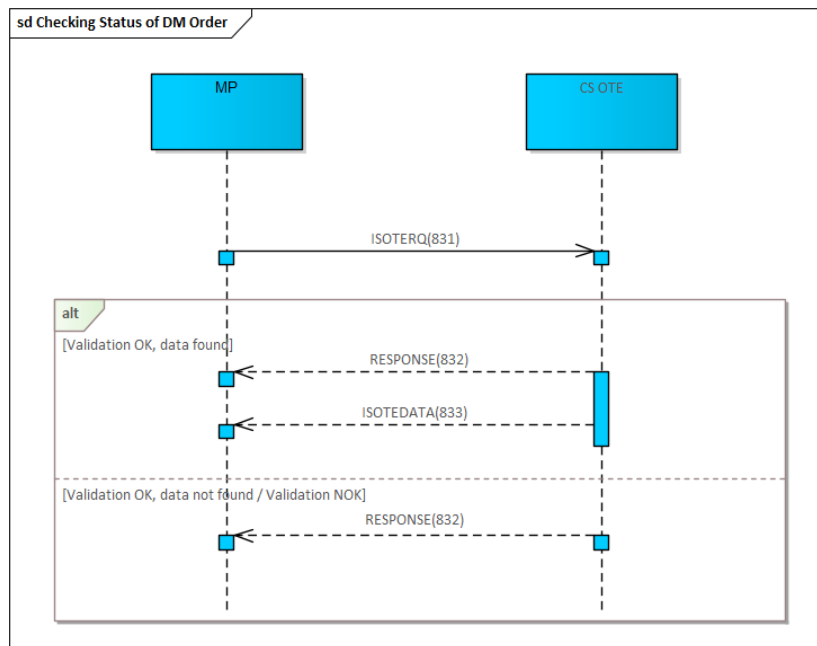

Figure 3 - Communication scenario - Checking status of DM Order

4.1.4. Data Request - DM Marginal Prices and Volume

The query will allow the resulting marginal prices and resulting volumes on the daily market for the selected delivery day to be determined. A single operation will contain just one request to find out the resulting prices and resulting volumes on the DT for a given delivery day, the response of which may be none or one result. OTE data formats are used in this communication scenario. The meaning of the individual items of the message formats used is defined within the chapter 4.2 *Content of DM Data Messages*.

As a result, 1 pair of messages is provided as part of the response:

- RESPONSE containing the result of the processing of the Marginal Price and Volume request to DT
- ISOTEDATA containing the marginal price and volume data on the DT, the data being provided at the resolutions at which orders can be placed on the delivery date.
 - This data copy report is not provided if marginal prices and volumes are not available on the DT for the requested delivery date
 - Data provided:
 - Resulting marginal prices on DT
 - Total traded volume of buying on the DT in a given delivery period, includes the agreed volume on the DT for 60min and 15min buying orders on the DT
 - The total traded volume of sales on the DT in a given delivery period, includes the agreed volume on the DT for 60min and 15min of the sales order on the DT
 - The total traded volume of a given market participant's buying on the DT in a given delivery period includes the agreed volume for both the 60min and 15min buying orders of a given market participant on the DT
 - The total traded volume of sales by the market participant on the DT in the delivery period, including the agreed volume for both 60min and 15min sales orders by the market participant on the DT

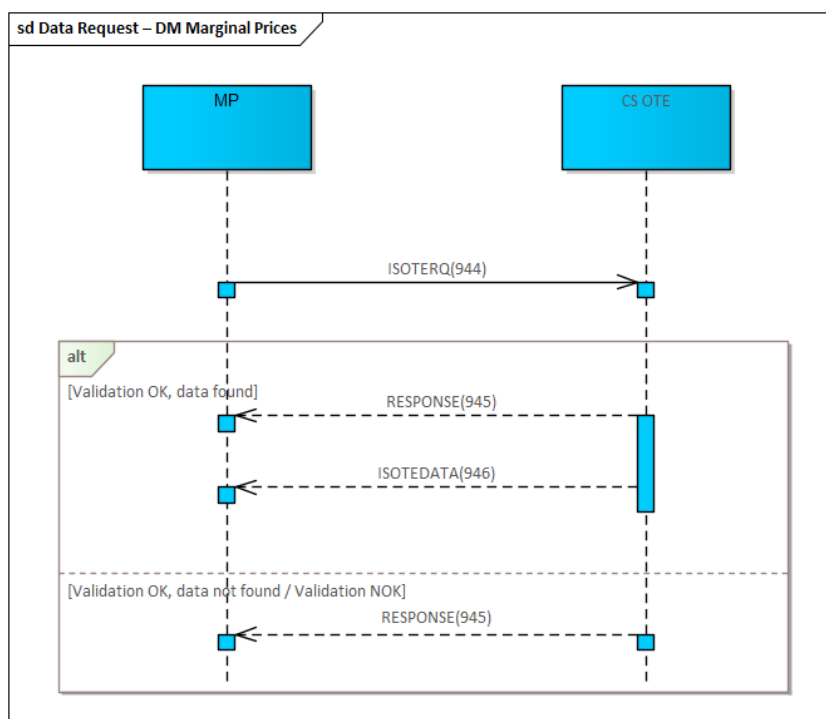

Figure 4 - Communication Scenario - Data Request - DM Marginal Prices

4.1.5. Data request - DM Capacity Data

The data request purpose is to get DM Capacity Data. One message contains exactly one request to get capacity data for a given delivery day, the outcome of which can be:

- either Capacity_OTEMarketDocument – containing capacity data for the required delivery day
- or Acknowledgment_MarketDocument – as a negative response in case capacity data is not available for a given delivery day or in case the request validation is not successful.

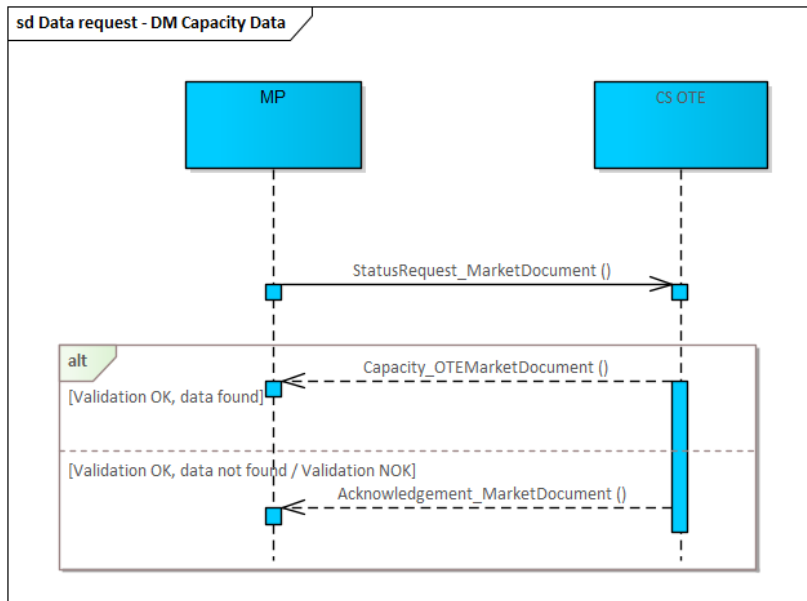

Figure 5 - Communication scenario - Data request - DM Capacity Data

4.2. Content of DM Data Messages

The chapter describes the content of data messages used in communication scenarios on DM with an emphasis on the use and description of the attributes of given data messages for the needs of the DM agenda. See also [2], where custom data message template files and their full definitions are available.

4.2.1. ISOTEDATA

Table 4 - Content of data messages DM - ISOTEDATA

Element/Attribute	Description	Data type or example ⁷	Usage in messages ⁸			
			811	821	813, 823, 833	946
ISOTEDATA						
/ Standard Message Header	A description of the standard header can be found in chapter 3.1.1 Standard OTE message header format	{/message-code=811 - creation/modification of orders; */message-code=813 - definition of created/modified orders; */message-code=821 - deleting order;	P	P	P	P

⁷ Example:

A01	Value example
A05	Constant
{A01; A10}	List of possible constants

⁸ Usage in messages: P = Mandatory item; V = Optional item; PP = Conditional item; N/A = Item not used

Element/Attribute	Description	Data type or example ⁷	Usage in messages ⁸			
			811	821	813, 823, 833	946
		*/message-code=823 - definition of canceled order; */message-code=833 - definition of queried order(s) */message-code=946 DM marginal prices and quantity}				
Reference						
*/id	Identification of the previous message in meaning of ISOTEDATA/ISOTEREQ request, for which the answer is being provided. Numeric entry: max. 35 digits.	xsd:string 76638	N/A	N/A	P	P
Trade						
		1..n				
*/trade-day	Delivery day in format yyyy-mm-dd	xsd:date 2020-06-18	P	N/A	P	P
*/trade-type	Type of order: • B - Buy; • S - Sell	xsd:string {B; S}	P	N/A	P	N/A
*/id	Order code. Integer value: min. value 1; 18 digits max	xsd:string 76638	V	P	P	N/A
*/version	Order version within CS OTE system . Together with the order code, they form a unique identification of the order in the CS OTE system. To modify a valid spot order, its code and version must be indicated. If the code and version are not filled in for the order, a new order will be created (with the new code and version 1). Derivative orders cannot be modified. If a code and version are not filled in for a derivative order, a new one will be created or an existing order is replaced (the new order is identical within derivative order, owner, delivery day and order class), the New Order will have the same code and with version n+1 (where n is the version of being replaced order). Integer value: max. 3 digits.	xsd:string 2	V	P	P	N/A
*/external-id	Order Id in the market participant's system. The item is mandatory in the case of entry/modification/cancellation of set of orders within one data message. Duplication of values is not checked within CS OTE, uniqueness must be ensured by the data provider. Integer value: min. value 1; 18 digits max.	xsd:string 120	PP	PP ⁹	PP	N/A
*/parent-external-id	Order Id in the market participant's system related to the parent block linked order. The item is mandatory in case of entering linked block orders within one data message. Integer value: min. value 1; 18 digits max.	xsd:string 500	PP	N/A	PP	N/A

⁹ In case of mass cancellation request (message 821) the value must correspond to a value of external-id of being cancelled order registered within CS OTE. Copy of data of cancelled order (message 823) could not reflect unexpectedly changed external-id value provided within cancellation request.

Element/Attribute	Description	Data type or example ⁷	Usage in messages ⁸			
			811	821	813, 823, 833	946
*/category	Block order category can be specified for spot orders only <ul style="list-style-type: none"> PBO – profile block order LPBO – linked profile block order (used only for message-codes 813, 823 and 833) CPBO – Cyclic profile block order (used only for messages 813, 823, 833) STD – for the standard order type FHO – flexible hourly order (listed only for historical orders data if applicable within message with message-code=833) 	xsd:string {PBO; LPBO; CPBO, FHO, STD}	P	N/A	P	N/A
*/loop-group	Identification of the participant's cyclical group of profile block orders on a given delivery day. Numeric field: min. 1 digit, max. 24 digits.	xsd:string 285	PP	N/A	PP	N/A
*/accept-ratio	The minimum acceptance ratio in all periods, given as a percentage (mandatory item only for profile block orders). Integer value: min. value 0, max. value 100, max. 3 digits.	xsd:string 59	PP	N/A	PP	N/A
*/actual-ratio	Actual acceptance ratio of executed quantity, for profile block orders only. Integer value: max. 3 digits. Note: Indicated only in the order definition data (message 833), provided that DM Marginal Prices have already been published.	xsd:string 59	N/A	N/A	PP	N/A
*/parent-block	The code of the active parent block order within the profile block orders of the given market participant, delivery day and order type (mandatory item only in case of a linked profile block order, provided that the given linked profile block order is not at the 1st level of linked orders hierarchy). Integer value: min. value 1; 10 digits max.	xsd:string 68358	PP	N/A	PP	N/A
*/excls-group	Identification of exclusive group of profile block order. Integer value: min. value 1, 24 digits max.	xsd:string 158	PP	N/A	PP	N/A
*/replacement	Flag whether the order has been replaced by a new version <ul style="list-style-type: none"> Y – yes, replaced; N – no, not replaced 	xsd:string {Y; N}	N/A	N/A	P	N/A
*/resolution	Time resolution of the periods of the order data <ul style="list-style-type: none"> PT15M – order entered in 15 minutes resolution PT60M – order entered in 60 minutes resolution 	xsd:string {PT15M; PT60M}	P	N/A	P	P
*/error-code	Identification of an error that may occur during the processing of the request. Individual identifiers will be defined by a code, see chapter 4.2.2.1 Errors/messages for the DM area - fulfillment of the code, result-code and error-code attributes. Integer value: max. 10 digits.	xsd:string 1009	N/A	N/A	P	N/A

Element/Attribute	Description	Data type or example ⁷	Usage in messages ⁸			
			811	821	813, 823, 833	946
*/sett-curr	Currency for settlement of the order on the day market: <ul style="list-style-type: none"> • CZK; • EUR 	xsd:string {CZK; EUR}	P	N/A	P	N/A
*/source-sys	Identification of the source system that initially received the order: <ul style="list-style-type: none"> • PXE • OTE 	xsd:string {PXE; OTE}	N/A	N/A	P	N/A
*/trade-session	Session identification: <ul style="list-style-type: none"> • DAM – Day Ahead Market 	xsd:string {DAM}	N/A	N/A	P	N/A
*/trade-state	Flag whether the order is: <ul style="list-style-type: none"> • V – Valid; • I – Invalid 	xsd:string {V, I}	N/A	N/A	P	N/A
*/trade-flag	The order cancelation flag: <ul style="list-style-type: none"> • Y – yes, canceled; • N – no, not canceled 	xsd:string {Y, N}	N/A	N/A	P	N/A
*/trade-market-flag	Market type flag: <ul style="list-style-type: none"> • SPT – spot; • DER – derivative 	xsd:string {SPT, DER}	V	N/A	P	N/A
*/util-flag	A flag determining the moment of financial security: <ul style="list-style-type: none"> • 0 - utilization of the order within the utilization window (first during D-2); • 1 - immediate order utilization (the order is utilized immediately as part of the request processing). If this item is not filled in, the system will automatically set the moment of financial security for the given order to the value 1 (immediate utilization), also applies to historical data.	xsd:int {0, 1}	V	N/A	P	N/A
TimeData	0..2					
*/datetime	Time stamp of order creation (required item) or Time stamp of order cancelation (mandatory item in the case of canceled order) According to ISO 8601, in UTC format, see chapter 3.1.2 Date and time values in messages.	xsd:dateTime 2020-06-18T16:32:03Z	N/A	N/A	P	N/A
*/datetime-type	Identifying the timestamp type of the order: <ul style="list-style-type: none"> • DTC – timestamp of creation • DTA – timestamp of cancelation 	xsd:string {DTA; DTC}	N/A	N/A	P	N/A
ProfileData	1..n					
*/profile-role	A list and description of the profiles used is provided in chapter 1.14.2.1.1 Identification of profiles DM. Alphanumeric item: max. 4 characters.	xsd:string BC05	P	N/A	P	P
*/unit	Unit related to the passed value for a given profile role: <ul style="list-style-type: none"> • MAW - for quantity BC01-25, BS01-25 • EUR/MWH - for prices BP01-25, SP20 	xsd:string {MAW; MWH; EUR/MWH}	P	N/A	P	P
Data	1..n					
*/period	Identification of the delivery period within given delivery day. Number of periods is resolution specific:	xsd:string 15	P	N/A	P	P

Element/Attribute	Description	Data type or example ⁷	Usage in messages ⁸				
			811	821	813, 823, 833	946	
	<ul style="list-style-type: none"> if resolution = PT15M, then the value of the period is in range 1 to 96 (eventually 1 to 92 in case of SCC day or 1 to 100 in case of LCC day, if resolution = PT60M, then the value of the period is in range 1 to 24 (eventually 1 to 92 in case of SCC day or 1 to 100 in case of LCC day). <p>For individual detail records, the item must be unique and must be sorted in ascending order. Integer value: min. value 1, max. 3 digits).</p>						
	*/value	<p>A value that depends on the profile-role:</p> <ul style="list-style-type: none"> In the case of quantity (BC01-25), a value with 1 decimal place is expected. In the case of executed quantity (BS01-25), a value with 1 decimal place is expected. It is not specified within order creation/modification request. In the case of price (BP01-25, SP20), a value with 2 decimal places is expected. For derivative orders, the price is not indicated. In the case of profiles SC60, SC61, SC62, SC63, a value to 3 decimal places is expected. <p>Numerical item with a precision of max. 5 decimal places (decimal separator: ".").</p>	xsd:string	P	N/A	P	P
	*/splitting	<p>Symptom of volumetric indivisibility of segment 1 clocks</p> <ul style="list-style-type: none"> N – indivisible by volume <p>Note: Indicated only in the copy of historical orders in profile BC01 (message 833) in the case when the order was indivisible by volume in the 1st segment.</p>	xsd:string {N}	N/A	N/A	(V)	N/A
	*/emergency-state	<p>Emergency state indicator:</p> <ul style="list-style-type: none"> ES – emergency state <ul style="list-style-type: none"> 15-minute order – an emergency state occurred during the given 15-minute period; 60-minute order – an emergency state occurred in all subordinate 15-minute periods of the given hour PES – partial emergency state <ul style="list-style-type: none"> 60-minute order – in some subordinate 15-minute periods of the given hour, a emergency state occurred <p>Note: Listed only in the transcript (message 833).</p>	xsd:string {ES; PES}	N/A	N/A	V	N/A
	Comment	<p>Comment on the order. Text entry: max. 100 characters.</p>	xsd:string	V	N/A	V	N/A
	Party						

Element/Attribute	Description	Data type or example ⁷	Usage in messages ⁸			
			811	821	813, 823, 833	946
id	Message owner identification (EAN code). Numeric entry: fixed length of 13 digits.	xsd:string 8591824000007	P	N/A	P	N/A
role	Role of the market participant: • TO – instruction owner	xsd:string TO	P	N/A	P	N/A

4.2.1.1 Identification of profiles DM

List of profiles used in DM messages:

Table 5 – List of profiles – DM messages

Use in a report	Profile	Unit	Meaning of profile	Note
*/message-code	*/profile-role	*/unit		
811, 813, 823, 833	BC01-25	MAW	Volume in a given segment (1-25) of the order	For each order period, the item must be sorted in ascending order. In the case of a block order, only the first segment (BC01) must be entered.
811, 813, 823, 833	BP01-25	EUR/MWH	Price in the segment (1-25) of the order	For each order period, the item must be sorted in ascending order. In the case of a block order, only the first segment (BP01) must be listed.
833	BS01-25	MAW	Agreed volume in a given segment (1-25) of the order (if the offer has been agreed and the DM reconciliation results have been published for that delivery day).	For each order period, the item must be sorted in ascending order. In the case of a block offer, only the first segment (BS01) must be entered. In the emergency state, the agreed quantity at the level of: <ul style="list-style-type: none"> 15-minute periods (for 15-minute orders) does not provide records for the given 15-minute period. 60-minute periods (for 60-minute orders) does not provide in the order transcript, i.e., the "BS" profile do not contain any records for the given 60-minute period if an emergency state occurred in at least one of the subordinate quarter-hour periods of the given 60-minute period.
946	SP20	EUR/MWH	Resulting marginal price per DM in a given delivery period	
946	SC60	MWH	Total traded volume of buying on the DM in a given delivery period.	Includes the agreed volume on DM for 60min and 15min purchase offers. In case of SN announcement in any given period, no traded volume will be provided in the description, i.e. the profile "SC60" will not contain any record for that period.
946	SC61	MWH	The total volume of sales traded on the DM in a given delivery period.	Includes the agreed volume on the DM for both the 60min and 15min selling orders. In case of SN announcement in any given period, no traded volume will be provided in the description, i.e. profile "SC61" will not contain any record for that period.
946	SC62	MWH	The total traded volume of a given participant's purchases on the DM in a given delivery period.	It includes the agreed volume for both 60min and 15min buying orders of a given market participant on the DM. In the case of a SN announcement in any given period, no traded volume will be provided in the description, i.e. the profile "SC62" will not contain any record for that period.
946	SC63	MWH	The total traded volume of sales of a given participant on the DM in a given delivery period.	It includes the agreed volume for both the 60min and 15min sales offers of the market participant on the DM.

Use in a report	Profile	Unit	Meaning of profile	Note
*/message-code	*/profile-role	*/unit		
				In case of a SN announcement in any given period, no traded volume will be provided in the description, i.e. the profile "SC63" will not contain any record for that period.

4.2.2. RESPONSE

Table 6 - Content of DM - RESPONSE data messages

Element/Attribute	Description	Data type or example ¹⁰	Usage in messages ¹¹
RESPONSE			
/ Standard Message Header	A description of the standard header is given in chapter 3.1.1 Standard OTE message header format.	{/message-code=812 - response to order creation/modification request; */message-code=822 - response to order cancelation request; */message-code=832 - response to order status request; */message-code=945 - response to DM marginal prices and quantity request}.	P
Reference			
*/id	Identification of the previous message in meaning of ISOTEDATA/ISOTEREQ request, for which the answer is being provided. Numeric entry: max. 35 digits.	xsd:string 76638	P
Reason			P
	Text description of messages/warnings/errors, see chapter 4.2.2.1 Errors/messages for the DM area - fulfillment of the code, result-code and error-code attributes.	(MSG5505) Query executed. No data found.	V
*/code	Message/warning/error number, see chapter 4.2.2.1 Errors/messages for the DM area - fulfillment of the code, result-code and error-code attributes. Integer value: min. value 1; max. 8 digits.	xsd:string 5505	P
*/type	Identification of the message type. Alphanumeric entry: fixed length 3 characters.	xsd:string A02	P
*/trade-id	Identification of the order. Integer value: min. value 1; 18 digits max.	xsd:string 317871	V
*/version	Order version. Integer value: min. value 1; 3 digits max.	xsd:string 1	V
*/external-id	Order Id in the market participant's system. Integer value: min. value 1; 18 digits max.	xsd:string 325489	V

¹⁰ Example:

A01	Value example
A05	Constant
{A01; A10}	List of possible constants

¹¹ Usage in messages: P = Mandatory item; V = Optional item

Element/Attribute	Description	Data type or example ¹⁰	Usage in messages ¹¹
*/result-code	Extended report/warning/error number. It is a 6-digit alphanumeric string in the form M<mxxxx>, where: <ul style="list-style-type: none"> • m - module code the result code is originating from: <ul style="list-style-type: none"> • 1 – Day-ahead Market • 0 – Other unclassified and system messages • xxxx – numerical identification of reports/warnings/errors, see the "code" attribute, list of error reports on DM, see chapter 4.2.2.1 Errors/messages for the DM area - fulfillment of the code, result-code and error-code attributes Alphanumeric entry: fixed length of 6 characters	xsd:string M15505	V

4.2.2.1. Errors/messages for the DM area - fulfillment of the code, result-code and error-code attributes

The chapter defines a list of warnings and error messages that can be expected in a message within the DM communication scenarios, with the resolution of the communication scenario in which it can occur. The first table entry is the value that can be found in the code attribute of the Reason XML element in the RESPONSE message, the second table entry defines a text message pattern describing the given warning/error that can be found in the Reason XML element of the RESPONSE message.

Table 7 - Errors/messages for the DM area - fulfillment of the code, result-code and error-code attributes

code	Description	Type ¹²	Creation / Modification	Deletion	Query
1009	Non-existent order unit.	E	*		
1116	A locked participant cannot perform any operations on the electricity market.	E	*	*	
1123	For message type %s1, only subscriber EIC code is supported in SenderIdentification.	E	*	*	*
1124	For message type %s1, only the EAN code of the subscriber is supported in the SenderIdentification item.	E	*	*	*
2000	Session terminated	E	*		
2004	The maximum amount of ordering participant has been exceeded.	E	*		
2009	The order price is lower than the minimum allowable price in the system.	E	*		
2010	The order price is higher than the maximum allowable price in the system.	E	*		
2011	The hourly quantity offered is lower than the minimum allowed in the system.	E	*		
2012	The hourly quantity offered is higher than the maximum allowed in the system.	E	*		
2014	In the buy order the prices in the segment must be strictly decreasing.	E	*		

¹² Type: E = Error message; I = Informative message; W = Warning

code	Description	Type ¹²	Creation / Modification	Deletion	Query
2015	In the sell order the prices in the segment must be strictly ascending.	E	*		
2019	The business day must be greater than the current day's date	E	*		
2020	There is no entry in the parameter table.	E	*		
2027	The order participant is not authorized for this type of bid.	E	*		
2030	A minimum income condition is not admissible for the second evaluation cycle.	E	*		
2038	The quantity is zero in all order hours.	E	*		
2200	The warranty limits are not met.	E	*	*	
2201	The product of quantity and price is zero in all supply hours.	E	*		
2260	Meets the guarantee: Bank Validation.	I	*		
2261	Meets the guarantee: The warranty limits are almost exhausted.	E	*	*	
2262	SFVOT - %d error occurred while verifying guarantees.	E	*	*	
2264	SFVOT – Warranty limits are currently locked. Please try again later.	E	*	*	
2290	The warranty limits of the Super-Subject are not met.	E	*	*	
2309	In the case of modification of the order, the code and version of the order must be filled in.	E	*		
2310	Error in order header: invalid block order category.	E	*		
2311	In the case of a derivative order, the block order category is not permitted.	E	*		
2312	In the case of a profile block order, there must be a fixed price in all hours of the block.	E	*		
2313	The minimum match rate must be in the range %s1 - 100.	E	*		
2314	Invalid exclusive group identifier.	E	*		
2315	The minimum level of the agreed quantity is allowed only in the case of a profile block order.	E	*		
2316	Exclusive group is only allowed in case of profile block order.	E	*		
2317	Deletion of linked block orders must proceed from the lowest level.	E		*	
2318	The order does not meet the conditions for modification.	E	*		
2319	Exclusive group identification must be unique within the day of delivery.	E	*		
2320	The derivative order cannot be modified.	E	*		
2322	Only 1 block can be specified for PBO orders.	E	*		
2323	Incorrect identification of the parent profile block order.	E	*		
2324	Only a PBO order can have a parent profile block order defined.	E	*		
2325	An exclusive group can only contain orders for one day of delivery.	E	*		
2328	A PBO may be part of no more than one block order group.	E	*		
2363	Maximum level of linked profile block orders exceeded, limit is %s.	E	*		
2364	The maximum number of exclusive subscriber groups has been exceeded for the given day of delivery, the limit is %s.	E	*		
2365	The maximum number of PBO orders in one exclusive group has been exceeded, the limit is %s.	E	*		
2366	The maximum number of PBO linked order families per market participant has been exceeded, the limit is %s.	E	*		

code	Description	Type ¹²	Creation / Modification	Deletion	Query
2367	The maximum number of linked PBO orders in one family has been exceeded, the limit is %s.	E	*		
2373	The participant is not a valid settlement entity.	E	*		
2374	When modifying the order, the exclusive group cannot be changed.	E	*		
2501	The time will change on Sunday.	I	*		
2502	Today is a time change.	I	*		
2531	The deletion date cannot be less than the date of the current session.	E	*		
2532	Order %s1 version %s2 has already been deleted and cannot be deleted again.	E	*		
2536	You have insufficient user rights to complete this operation.	E	*	*	
2538	Unable to load order for subscriber %s	E	*		
2604	Illegal quantity value.	E	*		
2605	Invalid prize value.	E	*		
2638	The order is not eligible for deletion.	E	*		
2641	Participant %s is not a valid settlement subject (from %d1 to %d2).	E	*	*	
2642	The participant is not authorized to participate in the daily market (from %d1 to %d2).	E	*	*	
2645	Error in order header: order block identification is required.	E	*		
2646	Error in order header: invalid order segment identifier.	E	*		
2648	The participant is not entitled to participate in the day market.	E	*	*	
2649	Error in order header: settlement currency code is required.	E	*		
2650	Error in order header: invalid settlement currency code.	E	*		
2663	Session for order entry is in not open.	E	*		
2665	Order Rejected: contains the hours in which the state of emergency was declared.	E	*		
2920	The order must not contain empty segments	E	*		
2923	The action was completed successfully.	I	*		
2924	Request %s is waiting for FS check, check the request queue.	I	*		
2929	No activity or default currency is set for the day of delivery!	E	*		
2941	No participant currency found. Return code:	E	*		
2948	Error in order header: invalid order market type.	E	*		
2949	Only PXE can enter/delete the FS order.	E	*		
2950	Error at hour %d: price must not be specified.	E	*		
2953	In the 2nd auction, only the periods for which the 2nd auction was announced can be changed.	E	*		
2954	The order cannot be deleted - it does not meet the criteria for deleting orders in the 2nd auction.	E	*		
3015	The user does not have the required permissions to perform this operation.	E	*	*	
3029	Participant %s is not registered as a market participant.	E	*	*	
3122	User %s does not exist.	E	*	*	*
3165	Unexpected deletion type.	E	*		
3183	Wrong comment.	E	*		
3204	The data contains illegal characters (ASCII-%s).	E	*		

code	Description	Type ¹²	Creation / Modification	Deletion	Query
3426	The 2nd auction was announced for delivery day %d1: Start of the 2nd auction session: GOT = %d2 End of session 2nd auction: GCT = %d3 2nd auction results publication time: GPT = %d4	I			
3427	Problem periods - Exceeding the upper limit %n1: Periods = %s1	I			
3428	Problem periods - lower limit exceeded %n2: Periods = %s2	I			
3570	Syntax error when validating order segments.	E	*		
3585	Error in order detail: zero price not allowed.	E	*		
3700	No detail has been entered for this order.	E	*		
3943	Failed system deletion of order %s1 on DT: %s2	E	*		
3945	Request canceled at CS	E	*		
4018	Error in order header: incorrect number of items.	E	*	*	
4019	Error in order header: the participant is mandatory.	E	*		
4023	Error in order header: invalid date.	E	*		
4024	Error in order header: order class is mandatory.	E	*		
4025	Error in order header: invalid order class.	E	*		
4029	Error in order detail: order period is mandatory.	E	*		
4030	Error in order detail: invalid order period.	E	*		
4031	Error in period %d: electricity is required.	E	*		
4033	Error in period %d: price is required.	E	*		
4039	Invalid order detail.	E	*		
4043	Data not found in processing table.	E	*	*	*
4044	Error in order header: order code is required.	E	*		
4046	Error in order header: order version is required.	E	*		
4050	Error reading detail for email.	E	*	*	*
4051	Invalid operation type.	E	*	*	
4063	Order not found.	E	*	*	
4066	Another user is working with the order, please try again later.	E	*	*	
4077	The order is not eligible for deletion.	E	*		
4079	An order can only be deleted by the owner of the order.	E	*		
4118	Invalid order header.	E	*		
4131	Error in order header: invalid %d. header item. %C	E	*	*	
5003	Incorrect number of separators.	E	*	*	*
5005	System error: %s	E	*	*	*
5007	Order with code %d1 and version %d2 has been loaded as invalid.	W	*		
5011	An error occurred while calling API functions. Error code = %s.	E	*	*	*
5019	The sender and owner of the data are not the same participant.	E	*	*	*
5020	Header error: "%s" is required.	E	*	*	*
5021	Error in detail: item "%s" is required.	E	*	*	*
5022	Header error: missing order code.	E	*		
5023	Header error: missing order version.	E	*		

code	Description	Type ¹²	Creation / Modification	Deletion	Query
5024	Header error: code and order version or date missing.	E	*		
5025	EAN/RMP conversion error. Non-existent Subscriber EAN (%s).	E	*	*	*
5026	EAN/RMP conversion error. Non-existing sender EAN (%s).	E	*	*	*
5027	RMP/EAN conversion error. Non-existent subscriber RMP (%s).	E	*	*	*
5028	Metadata error: creation '%s' is required.	E	*	*	*
5500	An order was created with code %d1 and version %d2.	I	*		
5503	Order with code %d1 and version %d2 has been deleted.	I		*	
5504	Query executed. Data found.	I			*
5505	Query executed. No data found.	I			*
5528	The order was deleted by the market operator.	I		*	
5537	The order was deleted by the system (SFVOT).	I		*	
5778	A parent PBO category item can be part of at most one block group.	E	*		
5824	Standard orders are not allowed for the specified delivery date.	E	*		
5825	Profile block orders are not allowed for the specified delivery date.	E	*		
5826	Profile block orders with exclusive group are not allowed for the specified delivery date.	E	*		
5827	Linked Profile block orders are not allowed for the specified delivery date.	E	*		
5828	The minimum acceptance rate must be 100.	E	*		
5829	It is not permitted to submit cycle profile block orders for the delivery date in question.	E	*		
5830	The minimum acceptance rate must be the same as the minimum acceptance rate for a paired cyclic order in the group.	E	*		
5831	The block of cycle groups is only allowed for profile block orders.	E	*		
5832	Invalid cycle group identifier.	E	*		
5833	The maximum number of orders in a single block cycle group has been exceeded.	E	*		
5834	The maximum number of orders for %s in the block cycle group has been exceeded.	E	*		
5835	The resolution of the order period must match the resolution of the paired cyclic order period within the group.	E	*		
5836	An incomplete cycle group with group ID %s; this group will not be included in the synchronization.	I		*	

4.2.2.2. Mass messages DM

Mass messages to participants of trading on DM are sent in specific situations during the course of DM. These are the following messages (identified by message-code):

Table 8 - Mass DM messages

Message-code	Message
904	SDAC_Delay in publication of capacity data

Message-code	Message
905	SDAC_Postponement of the deadline for receiving DM orders
906	(SDAC_Exc_02) Delay in publication of DM results
907	(SDAC_Exc_03b) Delay of DM results, possibility of Full Decoupling
908	(SDAC_Exc_04b) Full decoupling of markets - decoupling / (SDAC_Exc_05b) Full decoupling of markets - early Full Decoupling
956	(SDAC_UMM_02) Risk of partial disconnection (PD) at one or more borders
957	(SDAC_UMM_03) Decoupling one or more cross-border profiles
958	SDAC_Full decoupling of markets (premature decoupling) - detailed info
959	SDAC_Decoupling CZ area - detailed info
960	SDAC_Complete decoupling of the markets - detailed info
974	(SDAC_Exc_03a) Possibility of Partial Decoupling of markets
975	(SDAC_Exc_04a) Partial decoupling of markets - possibility of re-submission of orders
976	(SDAC_Exc_05a) Partial uncoupling of markets - early Partial Decoupling
977	(SDAC_Exc_06) Delay in publication of DT results - maximum price detected in LT, FI or SE
981	SDAC_Notice of change/advancement of deadline
989	SDAC_Publication of capacity data / Modification of capacity data
990	[SDAC_Exc_01] Exceeding price thresholds - possibility of re-submitting orders
997	SDAC_Publication of DM results

4.2.3. ISOTEREQ

Table 9 - Content of DM data messages – ISOTEREQ

Element/Attribute	Description	Data type or example ¹³	Usage in messages ¹⁴	
			831	944
ISOTEREQ				
/ Standard Message Header	A description of the standard header is given in Chapter 3.1.1 Standard OTE message header format.	{/message-code=831; */message-code=944}	P	P
Trade				
*/trade-day	Delivery day in yyyy-mm-dd format	xsd:date 2020-06-18	V	P
*/id	Order code. Integer value: min. value 1; 18 digits max.	xsd:string 76638	V	N/A
*/version	Order version. Integer value: max. 3 digits.	xsd:string 2	V	N/A
*/trade-market-flag	Market type indicator: • SPT – spot; • DER – derivative.	xsd:string {DER; SPT}	V	N/A

¹³ Example:

A01	Value example
A05	Constant
{A01; A10}	List of possible constants

¹⁴ Usage in messages: P = Mandatory item; V = Optional Item; N/A = Unused item

The request for orders (831) can be asked in two variants:

Table 10 - Inquiry about a specific order:

Element/Attribute	Usage in messages
*/id	Mandatory item
*/version	Mandatory item

Table 11 - Inquiry for all orders for a specified delivery day:

Element/Attribute	Usage in news
*/trade-day	Mandatory item

If the items of both variants are filled in the request, **variant No. 1 always takes precedence.**

4.2.4. StatusRequest_MarketDocument

Query on data of DM capacities

Table 12 - StatusRequest_MarketDocument (v4.1)

Element/Attribute	Description	Data type and example ¹⁵	Usage in messages ¹⁶
<i>StatusRequest_MarketDocument (v4.1)</i>			
mRID	The unique identifier of the StatusRequest document generated by the source system of the message sender.	xs:string(60) 20090501_A13_8591824010402_1	P
type	Message type of the document the status request sender is asking for <ul style="list-style-type: none"> A13 – Capacity data (Interconnection Capacity) 	string(3) A13	P
sender_MarketParticipant.mRID	Identification of the status request sender (EIC or EAN code)	xs:string (16) 11XJKL-CZ-----1 or 8591824099902	P
sender_MarketParticipant.mRID.codingScheme	Coding scheme of sender identification: <ul style="list-style-type: none"> A01 – for EIC code (Energy Identification Coding Scheme) A10 – for EAN code (European Article Number) 	string(3) {A01; A10}	P
sender_MarketParticipant.marketRole.type	Role of status request sender: <ul style="list-style-type: none"> A01 – Participant (Trade responsible party) 	string(3) A01	P
receiver_MarketParticipant.mRID	Identification of status request receiver (EIC or EAN code)	xs:string(16) 27XOTE-CZECHREPB or 8591824000007	P
receiver_MarketParticipant.mRID.codingScheme	Coding scheme of receiver identification: <ul style="list-style-type: none"> A01 – for EIC code (Energy Identification Coding Scheme) A10 – for EAN code (European Article Number) 	string(3) {A01; A10}	P

¹⁵ Example:

A01	Value example
A05	Constant
{A01; A10}	List of possible constants

¹⁶ Usage in messages: P = Mandatory item

Element/Attribute	Description	Data type and example ¹⁵	Usage in messages ¹⁶
receiver_MarketParticipant.marketRole.type	Role of status request receiver: <ul style="list-style-type: none"> A11 – Market operator 	string(3) A11	P
createdDateTime	Document creation timestamp. According to ISO 8601, in UTC format: YYYY-MM-DDTHH:MM:SSZ	xs:dateTime 009-04-30T07:10:30Z	P
<i>AttributeInstanceComponent</i>		<i>Structure</i>	
attribute	Name of searching attribute to specify domain identification of being requested document (case sensitive).	string domain.mRID	P
attributeValue	10Y1001C--00059P	string 10Y1001C--00059P	P
attributeValue.codingScheme	Coding scheme of domain identification of being requested document: <ul style="list-style-type: none"> A01 – for EIC code (Energy Identification Coding Scheme) 	string(3) A01	P
<i>AttributeInstanceComponent</i>		<i>Structure</i>	
attribute	Name of searching attribute to specify the required time interval of being requested document (case sensitive).	string requestedTimeInterval	P
attributeValue	Specification of the required time interval according to ISO 8601, in UTC format: YYYY-MM-DDThh:00Z/YYYY-MM-DD+1Thh:00Z The time interval is only possible within one day.	string 2009-04-30T22:00Z/2009-05-01T22:00Z	P

4.2.5. Capacity_OTEMarketDocument

Answer to the request for DM capacity data.

Table 13 - Capacity_OTEMarketDocument (CIM like Capacity_MarketDocument v8.1)

Element/Attribute	Description	Data type and example ¹⁷	Usage in messages ¹⁸
<i>Capacity_OTEMarketDocument</i>			
mRID	A unique message identifier of Capacity_OTEMarketDocument.	xs:string(60) 17XTSO-CS-----W-20220311F144v1	P
revisionNumber	Document version <1;999>	xs:string [1-9]([0-9]){0,2} 1	P
type	Message type: <ul style="list-style-type: none"> A13 – Capacity data (Interconnection Capacity) 	string(3) A13	P
process.processType	Process type: <ul style="list-style-type: none"> A07 - Capacity allocation 	string(3) A07	P
sender_MarketParticipant.mRID	Identification of the initial capacity data provider (CORE TSOs): <ul style="list-style-type: none"> 17XTSO-CS-----W 	xs:string(16) 17XTSO-CS-----W	P
sender_MarketParticipant.mRID.codingScheme	Coding scheme of identification of the initial capacity data provider:	String(3) A01	P

¹⁷ Example:

A01	Value example
A05	Constant
{A01; A10}	List of possible constants

¹⁸ Usage in messages: P = Mandatory item

Element/Attribute	Description	Data type and example ¹⁷	Usage in messages ¹⁸
	<ul style="list-style-type: none"> A01 – EIC code (Energy Identification Coding Scheme) 		
sender_MarketParticipant.marketRole.type	Sender's Role: <ul style="list-style-type: none"> A36 – Capacity Coordinator 	string(3) A36	P
receiver_MarketParticipant.mRID	Identification of initial capacity data receiver (EIC code of the OTE recipient): <ul style="list-style-type: none"> 17X100A100M003CI 	xs:string(16) 17X100A100M003CI	P
receiver_MarketParticipant.mRID.codingScheme	Coding scheme of identification of initial capacity data receiver: <ul style="list-style-type: none"> A01 – EIC code (Energy Identification Coding Scheme) 	string(3) A01	P
receiver_MarketParticipant.marketRole.type	Receiver's role: <ul style="list-style-type: none"> A11 – Market operator 	string(3) A11	P
createdDateTime	Document creation timestamp. According to ISO 8601, in UTC format: YYYY-MM-DDTHH:MM:SSZ	xs:dateTime 2022-03-10T10:42:07Z	P
received_MarketDocument.mRID	The unique identifier of the document to which the response is returned.	xs:string(60) 20190501_A13_8591824010402_1	P
<i>period.timeInterval¹⁹</i>	<i>Structure</i>		
start	Beginning of time interval of given delivery day at ISO 8601 UTC format: YYYY-MM-DDThh:00Z	xs:string(17) 2022-03-10T23:00Z	P
end	End of time interval of given delivery day at ISO 8601 UTC format: YYYY-MM-DDThh:00Z	xs:string(17) 2022-03-11T23:00Z	P
domain.mRID	Domain code: 10Y1001C--00059P	xs:string(18) 10Y1001C--00059P	P
domain.mRID.codingScheme	Coding scheme of the domain code: <ul style="list-style-type: none"> A01 – EIC code (Energy Identification Coding Scheme) 	string(3) A01	P
<i>FlowBasedTimeSeries</i>	<i>Structure (frequency:0..n)</i>		
mRID	A unique time series identifier generated by the sender's source system.	string(60) 41	P
businessType	Business type: <ul style="list-style-type: none"> A25 - General Capacity Information 	string(3) A25	P
product	8716867000016 - ActivePower	string(13) 8716867000016	P
balancingArea.mRID	EIC code, balancing area for which flow-based data is provided	xs:string(18) 10Y1001C--00059P	P
balancingArea.mRID.codingScheme	The format in which the balancing area is listed: <ul style="list-style-type: none"> A01 – EIC code (Energy Identification Coding Scheme) 	string(3) A01	P
measurement_Unit.name	Unit of quantity <ul style="list-style-type: none"> MAW (Mega watt) 	string(3) MAW	P
<i>Period</i>	<i>Structure (frequency: 1..n)</i>		
<i>timeInterval²⁰</i>	<i>Structure</i>		
start	Beginning of time interval of given delivery day at ISO 8601 UTC format: YYYY-MM-DDThh:00Z	xs:string(17) 2022-03-10T23:00Z	P
end	End of time interval of given delivery day at ISO 8601 UTC format: YYYY-MM-DDThh:00Z	xs:string(17) 2022-03-11T23:00Z	P

¹⁹ The time interval (start-end) is within one day.

²⁰ The time interval corresponds to the interval defined in the Capacity_OTEMarketDocument header

Element/Attribute		Description	Data type and example ¹⁷	Usage in messages ¹⁸
	resolution	Period resolution: <ul style="list-style-type: none"> PT60M - hourly interval PT15M – 15 minutes interval 	xs:duration {PT60M; PT15M}	P
	<i>Point</i>	<i>Structure (1..n)</i>		
	position	A sequence starting at 1. There are as many points as can fit into a given time interval for a given resolution [(timeInterval.end - timeInterval.start)/resolution]: <ul style="list-style-type: none"> For 15 min. resolution 1..96 (92/100 – on transition days) points For 60 min. resolution: 1..24 (23/25 – on transition days) points 	xs:integer; <1;999999> 5	P
	<i>Constraint</i>	<i>Structure (1..n)</i>		
	constraint.mRID	Unique identifier of a critical network element; range: <1;999999>	string (max. 9 number) 010017286	P
	RAM	The remaining available margin (RAM) of a critical network element, which, together with the electricity transmission distribution factor for the given area and the given critical network element, limits the resulting flow to/from the given area on this critical network element (accuracy: 11.5).	xs:decimal 298	P
	<i>PTDF</i>	<i>Structure (1..n)</i>		
	PTDFFactor	The Power Transfer Distribution Factor (PTDF) for a given area and a given critical network element, together with the available backup of the critical network element, limits the resulting flow to/from the given area on that critical network element (accuracy: 11.5, range: <-1 ;+1).	xs:decimal -0.00116	P
	<i>Hub</i>	<i>Structure</i>		
	hub.mRID	EIC code of the delivery area to which the PTDF values relate	xs:string(18) 10YAT-APG-----L	P
	hub.mRID.codingScheme	The coding scheme in which the PTDF delivery area code is given: <ul style="list-style-type: none"> A01 – EIC code (Energy Identification Coding Scheme) 	string(3) A01	P

4.2.6. Acknowledgement_MarketDocument

Confirmation of receipt of request for DM capacity data.

Table 14 - Acknowledgement_MarketDocument (v8.1)

Element/Attribute		Description	Data type and example ²¹	Usage in messages ²²
<i>Acknowledgement_MarketDocument (v8.1)</i>				
	mRID	Unique identifier of the Acknowledgment document generated by the source system of the sender.	xs:string(60) 20190501_A13_8591824000007_1	P

²¹ Example:

A01	<i>Value example</i>
A05	<i>Constant</i>
{A01; A10}	<i>List of possible constants</i>

²² Usage in messages: P = Mandatory item N/A = Not used

Element/Attribute	Description	Data type and example ²¹	Usage in message ²²
createdDateTime	Document creation timestamp. According to ISO 8601, in UTC format: YYYY-MM-DDTHH:MM:SSZ	xs:dateTime 2019-05-01T07:10:30Z	P
sender_MarketParticipant.mRID	Identification of the sender of the document (EIC or EAN code)	xs:string(16) 27XOTE-CZECHREPB or 8591824000007	P
sender_MarketParticipant.mRID.codingScheme	Coding scheme of identification of the sender: <ul style="list-style-type: none"> A01 - Energy Identification Coding Scheme (EIC) A10 – for EAN 	string(3) {A01; A10}	P
sender_MarketParticipant.marketRole.type	Sender's role: <ul style="list-style-type: none"> A11 – Market operator 	string(3) A11	P
receiver_MarketParticipant.mRID	Receiver identification (EIC or EAN code)	xs:string(16) 11XJKL-CZ-----1 or 8591824099902	P
receiver_MarketParticipant.mRID.codingScheme	Coding scheme of receiver identification: <ul style="list-style-type: none"> A01 - Energy Identification Coding Scheme (EIC) A10 – for EAN 	string(3) {A01; A10}	P
receiver_MarketParticipant.marketRole.type	Receiver's role: <ul style="list-style-type: none"> A01 – Participant (Trade responsible party) 	string(3) {A01}	P
received_MarketDocument.mRID	The unique identifier of the request document to which the response is returned.	xs:string(60) 20190501_A13_8591824010402_1	P
received_MarketDocument.type	Message type of requested document within status request to which the answer is returned: A13 – Capacity data (Interconnection Capacity)	string(3) {A13}	P
received_MarketDocument.createdDateTime	The timestamp of the creation of the data request document to which the response is provided. According to ISO 8601, in UTC format: YYYY-MM-DDTHH:MM:SSZ	xs:dateTime 2019-05-01T07:11:05Z	P
Reason		Structure (frequency: 1..n)	
code	Return codes (according to the CIM standard) identifying errors at the document header level.	string(3) A94	P
text	Detailed description of the error.	xs:string(512) Invalid message type.	P

4.2.6.1. Acknowledgement_MarketDocument (v8.1) – return codes in the Reason element for the DM area

Return codes and their detailed description in the Acknowledgement_MarketDocument (EAD) for the DM area:

Table 15 - Acknowledgement_MarketDocument (v8.1) – Return codes of the Reason.code, Reason.text attributes for the DM region

code	text
999	System error
A02	Error when validating XML file. %s
A04	Invalid time interval.
A51	Message identification or version conflict.
A53	Invalid receiver role.
A53	Invalid receiver coding scheme.

code	text
A53	Invalid receiver identification.
A69	Attribute %s is mandatory.
A78	Invalid sender role.
A78	Invalid sender coding scheme.
A78	Invalid sender identification.
A80	Invalid domain.
A94	Invalid requested document type.
A94	Duplicate attributes specified.
A94	Data capacity are not available, delivery date is not yet open for trading.
A94	Invalid auction identification.

5. Intraday Auctions (IDA)

5.1. IDA Communication Scenarios

The schematic representation of communication scenarios does not take into consideration specific technicalities related to the relevant web service and does not address specific differences in Server-Server and Client-Server communication, for the sake of simplicity it only shows in which message format the MP transmits the given request and which message format is provided as a response.

The methods of communication for individual IDA communication scenarios are summarized in the following table, a detailed description of the mentioned methods of communication and the relevant web services is given in [1].

Table 16 – Communication methods for communication scenarios IDA

Communication scenario	Method of communication
Creation/Modification of IDA Order(chapter 5.1.1)	Asynchronous communication scenario
Cancelation of IDA Order (chapter 5.1.2)	Asynchronous communication scenario
Checking Status of IDA Order (chapter 5.1.3)	Asynchronous communication scenario
Data Request - IDA Marginal Prices (chapter 5.1.4)	Asynchronous communication scenario
Data Request - IDA Capacity Data (chapter 5.1.5)	Asynchronous communication scenario

5.1.1. Creation/Modification of IDA Order

The communication scenario enables creation or modification (replacement) of the IDA order(s). Within this communication scenario, OTE data formats are used. The meaning of the individual items of the message formats used is defined within the chapter 5.2 *Content of IDA Data Messages*.

One creation (or modification) request may contain creation (or modification) of any number of orders. Following messages may be provided back as an outcome of the order creation/modification request:

- RESPONSE containing a result of the order creation/modification request processing, it is always provided
- ISOTEDATA containing a full definition of the created/modified order

One pair of these messages is provided separately for each individual order of the order creation/modification request, and only if a condition of successful formal validation is met. If the formal validation condition is not met, only a negative RESPONSE message is returned for each rejected order. In case the formal validation of a given order is successful, but there is MP’s insufficient financial security indicated for the given order, a negative RESPONSE message is returned for such rejected order with insufficient financial security alongside with ISOTEDATA message comprising full definition of the given order created/modified as invalid.

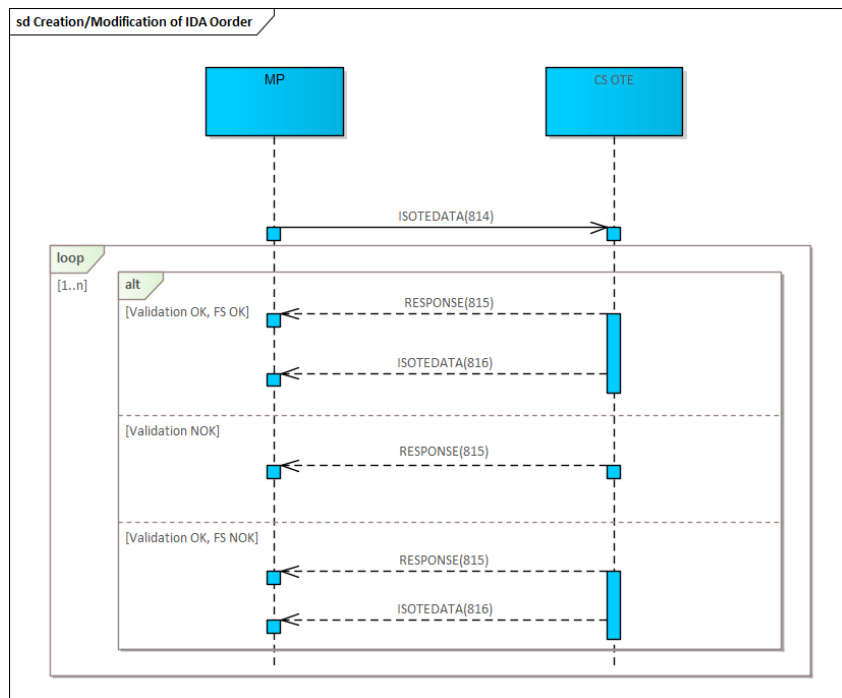

Figure 6 - Communication scenario - Creation/Modification of IDA Order

5.1.2. Cancellation of IDA Order

The communication scenario allows cancellation of IDA order, or mass cancellation of IDA orders. Within this communication scenario, OTE data formats are used. The meaning of the individual items of the message formats used is defined within the chapter 5.2 *Content of IDA Data Messages*.

One message may contain a request to cancel any number of orders.

Following messages may be provided back as an outcome of the order(s) cancellation request:

- RESPONSE containing the result of the order cancellation request processing, it is always provided
- ISOTEDATA containing a full definition of the canceled order

One pair of these messages is provided separately for each individual being canceled order, and only if the condition of successful formal validation is met. If the formal validation of the given order is not successful, only a RESPONSE message is returned for such order.

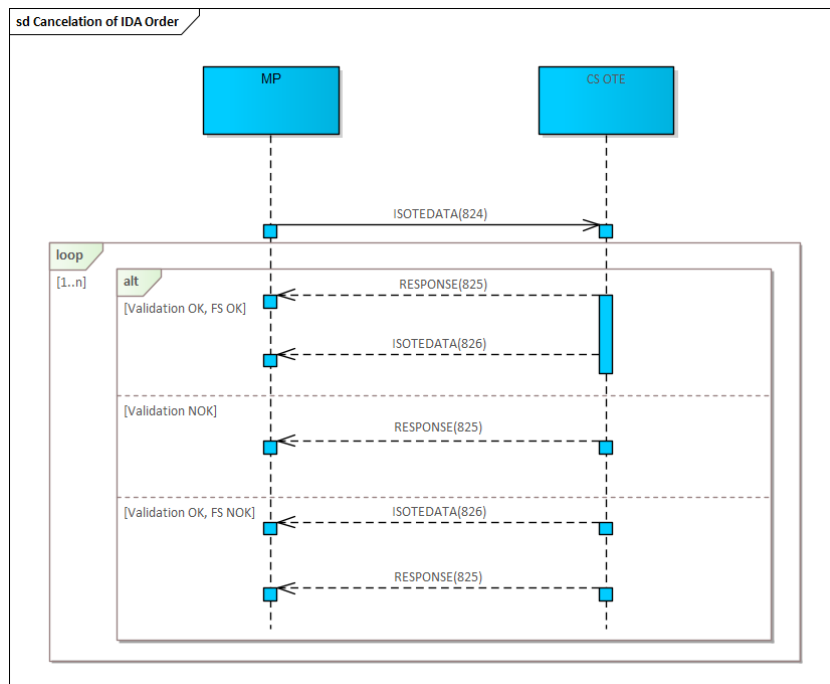

Figure 7 - Communication scenario - Cancellation of IDA Order

5.1.3. Checking Status of IDA Order

The communication scenario purpose is to find out the status of any specific IDA order (in case the request selection criteria refer to specific order id and order version values), or a set of IDA orders (in case the request selection criteria refer to a specific delivery day).

One message contains exactly one request with specific query criteria to get full order definition data, the result of which can be no order (invalid selection criteria), or just one order (for order id and version specified) or a set of orders (for the required delivery day and auction specified) . Within this communication scenario, OTE data formats are used. The meaning of the individual items of the message formats used is defined within the chapter 5.2 *Content of IDA Data Messages*.

One pair of following messages may be provided back as an outcome of IDA Order status request:

- RESPONSE containing the result of the IDA Order status request processing, it is always provided
- ISOTEDATA containing full definition of the being asked IDA Order, or being asked set of IDA Orders
 - this message is not provided if no order matches the selection criteria of the request

In case a formal validation of the request is not successful, only a negative RESPONSE message is returned.

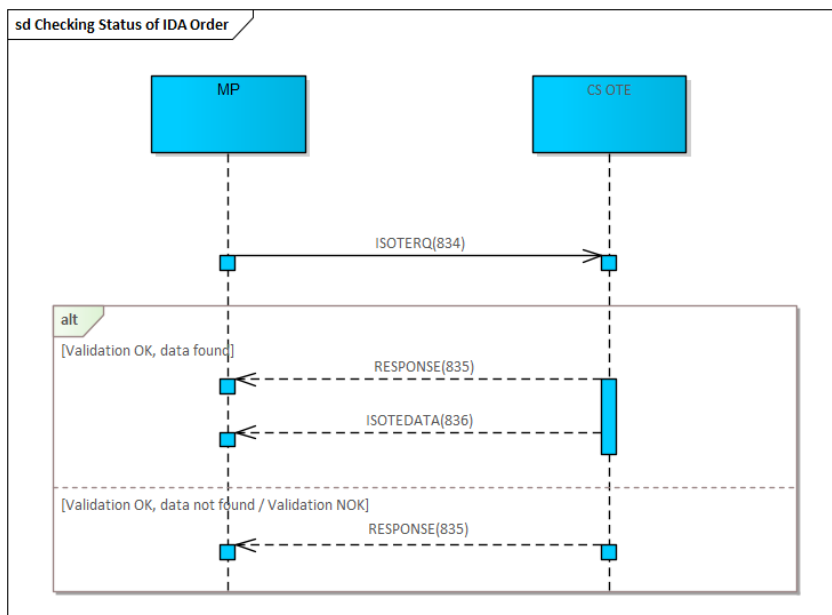

Figure 8 - Communication scenario - Checking status of IDA Order

5.1.4. Data Request - IDA Marginal Prices

The data request purpose is to get Marginal prices achieved at IDA. One request contains exactly one query to get resulting marginal prices for a given delivery day, all IDA auctions or a specific IDA auction, the answer to which can be none or one result. Within this communication scenario, OTE data formats are used. The meaning of the individual items of the message formats used is defined within the chapter 5.2 *Content of IDA Data Messages*.

One pair of following messages may be provided back as an outcome of the data request for IDA Marginal Prices:

- RESPONSE containing the result IDA Marginal Prices request processing, it is always provided
- ISOTEDATA containing IDA Marginal Prices data
 - This message is not provided if IDA Marginal Prices are not yet available for the being requested delivery day and IDA auction

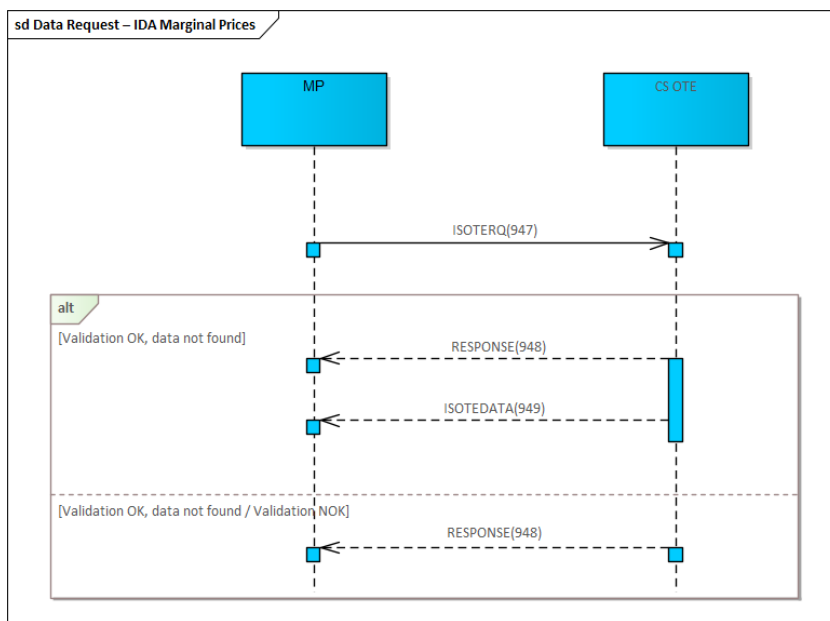

Figure 9 - Communication Scenario - Data Request - IDA Marginal Prices

5.1.5. Data Request - IDA Capacity Data

The data request purpose is to get IDA Capacity Data of a specific IDA auction and given delivery day. One message contains exactly one request to get capacity data for a given delivery day and IDA auction, the outcome of which can be:

- either Capacity_OTEMarketDocument – containing capacity data for the required delivery day and a specific IDA auction, this message is not provided if the required IDA auction capacity data are not yet available for given delivery day.
- or Acknowledgment_MarketDocument – as a negative response in case capacity data are not available for the specified criteria or in case the request validation is not successful.

The meaning of the individual items of the message formats used is defined within the chapter 5.2 *Content of IDA Data Messages*.

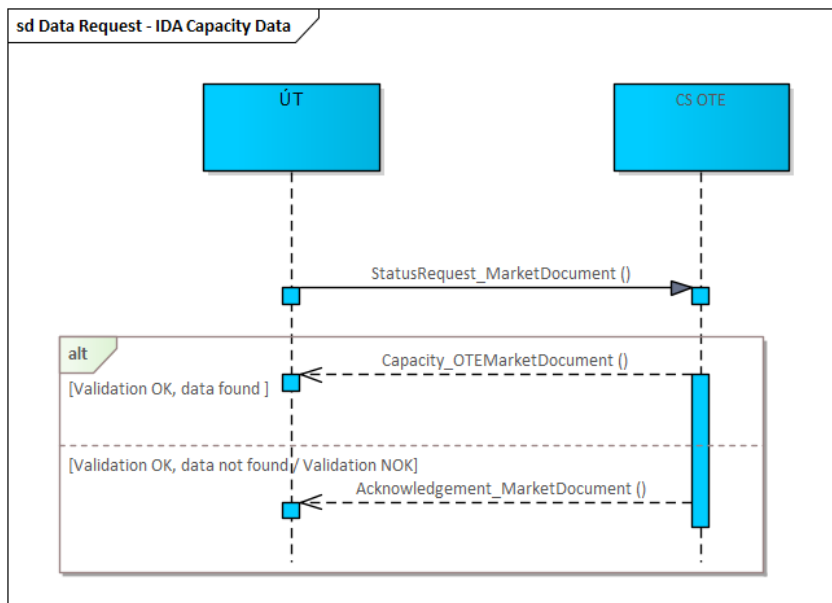

Figure 10 - Communication scenario - Data Request - IDA Capacity Data

5.2. Content of IDA Data Messages

The chapter describes the content of data messages used in communication scenarios within IDA. See also [2] where custom data message template files and their full definitions are available.

5.2.1. ISOTEDATA

Table 17 - Data message content IDA – ISOTEDATA

Element/Attribute	Description	Data type or example ²³	Usage in messages ²⁴			
			814	824	816, 826, 836	949
ISOTEDATA						
/ Standard Message Header	A description of the standard header can be found in chapter 3.1.1 Standard OTE message header format	{/message-code=814 - creating/modifying the order; */message-code=816 – definition of created/modified orders; */message-code=824 – order deletion; */message-code=826 – definition of canceled orders; */message-code=836 – definition of queried orders */message-code=949 - IDA marginal price}	P	P	P	P

²³ Example:

A01	Value example
A05	Constant
{A01; A10}	List of possible constants

²⁴ Usage in messages: P = Mandatory item; V = Optional Item; PP = Conditional Item; N/A = Unused item

Element/Attribute	Description	Data type or example ²³	Usage in messages ²⁴			
			814	824	816, 826, 836	949
Reference						
*/id	Identification of the previous message in meaning of ISOTEDATA/ISOTEREQ request, for which the answer is being provided. Numeric entry: max. 35 digits.	xsd:string 76638	N/A	N/A	P	P
Trade 1..n						
*/trade-day	Delivery day in yyyy-mm-dd format	xsd:date 2020-06-18	P	N/A	P	P
*/trade-type	Order type: <ul style="list-style-type: none"> B - Buy; S - Sell 	xsd:string {B; S}	P	N/A	P	N/A
*/id	Order code. Integer value: min. value 1; 18 digits max	xsd:string 76638	V	P	P	N/A
*/version	Order version within CS OTE system. Together with the order code, they form a unique identification of the order in the CS OTE system. To modify a valid spot order, its code and version must be indicated. The new order will have the same id and version n+1 (where n is the version of the being replaced order). If the code and version are not filled in for the order, a new order will be created (with the new code and version 1). Integer value: max. 3 digits.	xsd:string 2	V	P	P	N/A
*/external-id	Order Id in the market participant's system The item is mandatory in case of entry/modification/cancellation of set of orders within one data message. Duplication of values is not checked within CS OTE, uniqueness must be ensured by the data provider. Integer value: min. value 1; 18 digits max.	xsd:string 120	PP	PP ²⁵	PP	N/A
*/parent-external-id	Order id in the market participant's system related to the parent block linked order. The item is mandatory in case of entering linked block orders within one data message. Integer value: min. value 1; 18 digits max.	xsd:string 500	PP	N/A	PP	N/A
*/category	Block order category <ul style="list-style-type: none"> PBO – profile block order LPBO – linked profile block order (used only for message-codes 816, 826 and 836) STD – for the standard order type 	xsd:string {LBO; LPBO; STD}	P	N/A	P	N/A
*/accept-ratio	The minimum acceptance ratio in all periods, given as a percentage (mandatory item only for profile block orders). Integer value: max. 3 digits.	xsd:string 59	PP	N/A	PP	N/A
*/actual-ratio	Actual acceptance ratio of executed quantity, for profile block orders only. Integer value: max. 3 digits.	xsd:string 59	N/A	N/A	PP	N/A

²⁵ In case of mass cancellation request (message 824) the value must correspond to a value of external-id of being cancelled order registered within CS OTE. Copy of data of cancelled order (message 826) could not reflect unexpectedly changed external-id value provided within cancellation request.

Element/Attribute	Description	Data type or example ²³	Usage in messages ²⁴			
			814	824	816, 826, 836	949
	Note: Indicated only in the order definition data (message 836), provided that IDA Marginal Prices for the given auction have already been published.					
*/parent-block	The code of the active parent block order within the profile block orders of the given market participant, delivery day and order type and auction (required only in the case of a linked profile block order, provided that the given linked profile block order is not at the 1st level of linked orders). Integer value: min. value 1; 10 digits max.	xsd:string 68358	PP	N/A	PP	N/A
*/excls-group	Identification of exclusive group of profile block order Integer value: min. 1 digit, max. 24 digits.	xsd:string 158	PP	N/A	PP	N/A
*/replacement	Flag whether the order has been replaced by a new version <ul style="list-style-type: none"> Y – yes, replaced; N – no, not replaced 	xsd:string {Y; N}	N/A	N/A	P	N/A
*/resolution	Time resolution of the periods of the order data <ul style="list-style-type: none"> PT15M – order entered in 15 minutes resolution PT60M – order entered in 60 minutes resolution 	xsd:string {PT15M; PT60M}	P	N/A	P	P
*/error-code	Identification of an error that may occur during the processing of the request. Individual identifiers will be defined by a code list, see chapter 5.2.2.1 Errors/Reports for IDA Area - Attribute Fulfillment code, result-code and error-code Integer value: max. 10 digits.	xsd:string 1009	N/A	N/A	P	N/A
*/sett-curr	Currency for the settlement of the IDA order: <ul style="list-style-type: none"> CZK; EUR 	xsd:string {CZK; EUR}	P	N/A	P	N/A
*/source-sys	Identifying the source system that initially received the order: <ul style="list-style-type: none"> OTE 	xsd:string {OTE}	N/A	N/A	P	N/A
*/trade-session	Auction identification for a given delivery day: <ul style="list-style-type: none"> IDA1 – First IDA Auction IDA2 – Second IDA Auction IDA3 – Third IDA Auction 	xsd:string {IDA1; IDA2; IDA3}	P	N/A	P	P
*/trade-state	Flag whether the order: <ul style="list-style-type: none"> V – Valid; I – Invalid 	xsd:string {V, I}	N/A	N/A	P	N/A
*/trade-flag	Order deletion flag: <ul style="list-style-type: none"> Y – yes, canceled; N – no, not canceled 	xsd:string {Y, N}	N/A	N/A	P	N/A
*/trade-market-flag	Market type flag: <ul style="list-style-type: none"> SPT – spot; 	xsd:string {SPT}	V	N/A	P	N/A
*/util-flag	A flag determining the moment of financial security: <ul style="list-style-type: none"> 1 - immediate order utilization (the order is utilized immediately as part of the request processing). If this item is not filled in, the system will automatically set the moment of financial	xsd:int {1}	V	N/A	P	N/A

Element/Attribute	Description	Data type or example ²³	Usage in messages ²⁴				
			814	824	816, 826, 836	949	
	security to the value 1 (immediate utilization) for the given order						
	TimeData	0..2					
	*/datetime	Time stamp order creation (required item) or Time stamp for order cancelation (mandatory item in the case of canceled order) According to ISO 8601, in UTC format, see chapter 3.1.2 Date and time values in messages.	xsd:dateTime 2020-06-18T16:32:03Z	N/A	N/A	P	N/A
	*/datetime-type	Identifying the type of order timestamp: <ul style="list-style-type: none"> DTC - timestamp of creation DTA - timestamp of cancelation 	xsd:string {DTA; DTC}	N/A	N/A	P	N/A
	ProfileData	1..n					
	*/profile-role	Segment identification for orders: <ul style="list-style-type: none"> BC01-25 Oder Segment Identification (Segment 1 to 25) - Quantity BP01-25 Order segment identification (segment 1 to 25) – order price BS01-25 Order segment identification (segment 1 to 25) - executed quantity (provided that the order was executed and the IDA matching results were published for the given delivery day and the given IDA auction). It is not specified for order creation/modification request. Note: In case of announcement of ES in some periods, no executed quantity info will be provided in the order definitions (message-code 836) for the given periods, i.e. no entry with profile "BS" will be provided for the given periods. Segment identification for marginal prices: <ul style="list-style-type: none"> SP20 - marginal price The item must be sorted in ascending order. In the case of a block order (order category PBO or LPBO), only the first segment must be listed. Alphanumeric entry: max. 4 characters.	xsd:string BC05	P	N/A	P	P
	*/unit	The unit relative to the passed value for the given profile role: <ul style="list-style-type: none"> MAW - for quantity BC01-25, BS01-25 EUR/MWH - for prices BP01-25, SP20 	xsd:string {MAW; EUR/MWH}	P	N/A	P	P
	Data	1..n					
	*/period	Identification of the delivery period within given delivery day. Number of periods is resolution specific: <ul style="list-style-type: none"> if resolution = PT15M, then the value of the period is in range 1 to 96 (eventually 1 to 92 in case of SCC day or 1 to 100 in case of LCC day, if resolution = PT60M, then the value of the period is in range 1 to 24 	xsd:string 15	P	N/A	P	P

Element/Attribute	Description	Data type or example ²³	Usage in messages ²⁴			
			814	824	816, 826, 836	949
	(eventually 1 to 92 in case of SCC day or 1 to 100 in case of LCC day). For individual detail records, the item must be unique and must be sorted in ascending order. Integer value: min. value 1, max. 3 digits).					
*/value	A value that depends on the profile-role: <ul style="list-style-type: none"> In the case of quantity (BC01-25), a value with 1 decimal place is expected. In the case of executed quantity (BS01-25), a value with 1 decimal place is expected. It is not specified within order creation/modification request. In the case of price (BP01-25, SP20), a value with 2 decimal places is expected. Numerical item with a precision of max. 5 decimal places (decimal separator: ".").	xsd:string	P	N/A	P	P
*/emergency-state	Emergency state indicator: <ul style="list-style-type: none"> ES – emergency state <ul style="list-style-type: none"> 15-minute order – an emergency state occurred during the given 15-minute period; 60-minute order – an emergency state occurred in all subordinate 15-minute periods of the given hour PES – partial emergency state <ul style="list-style-type: none"> 60-minute order – in some subordinate 15-minute periods of the given hour, a emergency state occurred Note: Listed only in the transcript (message 836).	xsd:string {ES; PES}	N/A	N/A	V	N/A
Comment	Comment on the order. Text entry: max. 100 characters.	xsd:string	V	N/A	V	N/A
Party						
id	Message owner identification (EAN code). Numeric entry: fixed length of 13 digits.	xsd:string 8591824000007	P	N/A	P	N/A
role	Role of the market participant: <ul style="list-style-type: none"> TO – instruction owner 	xsd:string TO	P	N/A	P	N/A

4.2.1.2 Identification of profiles IDA

List of profiles used in IDA messages:

Table 18 – List of profiles – IDA messages

Use in a report	Profile	Unit	Meaning of profile	Note
814, 816, 826, 836	BC01-25	MAW	Volume in a given segment (1-25) of the order	For each order period, the item must be sorted in ascending order. In the case of a block order, only the first segment (BC01) must be entered.

Use in a report	Profile	Unit	Meaning of profile	Note
*/message-code	*/profile-role	*/unit		
814, 816, 826, 836	BP01-25	EUR/MWH	Price in the segment (1-25) of the order	For each order period, the item must be sorted in ascending order. In the case of a block order, only the first segment (BP01) must be listed.
836	BS01-25	MAW	Agreed volume in a given segment (1-25) of the order (if the offer has been agreed and the DM reconciliation results have been published for that delivery day).	For each order period, the item must be sorted in ascending order. In the case of a block offer, only the first segment (BS01) must be entered. In the emergency state, the agreed quantity at the level of: <ul style="list-style-type: none"> 15-minute periods (for 15-minute orders) do not provide any records for the given 15-minute period. 60-minute periods (for 60-minute orders) do not provide in the order transcript, i.e., the "BS" profile does not contain any records for the given 60-minute period if an emergency state occurred in at least one of the subordinate quarter-hour periods of the given 60-minute period.
949	SP20	EUR/MWH	Resulting marginal price per DM in a given delivery period	
949	SC60	MWH	Total traded volume of buying on the DM in a given delivery period.	Includes the agreed volume on DM for 60min and 15min purchase offers. In case of SN announcement in any given period, no traded volume is provided in the description, i.e. the profile "SC60" do not contain any record for that period.
949	SC61	MWH	The total volume of sales traded on the DM in a given delivery period.	Includes the agreed volume on the DM for both the 60min and 15min selling orders. In case of SN announcement in any given period, no traded volume is provided in the description, i.e. profile "SC61" does not contain any record for that period.
949	SC62	MWH	The total traded volume of a given participant's purchases on the DM in a given delivery period.	It includes the agreed volume for both 60min and 15min buying orders of a given market participant on the DM. In the case of a SN announcement in any given period, no traded volume is provided in the description, i.e. the profile "SC62" does not contain any record for that period.
949	SC63	MWH	The total traded volume of sales of a given participant on the DM in a given delivery period.	It includes the agreed volume for both the 60min and 15min sales offers of the market participant on the DM. In case of a SN announcement in any given period, no traded volume is provided in the description, i.e. the profile "SC63" does not contain any record for that period.

5.2.2. RESPONSE

Table 19 - Content of IDA - RESPONSE data messages

Element/Attribute	Description	Data type or example ²⁶	Usage in messages ²⁷
RESPONSE			
/Standard Message Header	A description of the standard header can be found in chapter 3.1.1 Standard OTE message header format	{/message-code=815 - response to the order creation/modification request; */message-code=825 - response to order cancelation request; */message-code=835 - response to order status request; */message-code=948 - the response to the IDA marginal prices and quantity request}	P
Reference			
*/id	Identification of the previous message in meaning of ISOTEDATA/ISOTEREQ request, for which the answer is being provided. Numeric entry: max. 35 digits.	xsd:string 76638	P
Reason			P
	Text description of reports/warnings/errors, see chapter 5.2.2.1 Errors/Reports for IDA Area - Attribute Fulfillment code, result-code and error-code	(MSG5505) Query executed. No data found.	V
*/code	Report/alert/error number, see chapter 5.2.2.1 Errors/Reports for IDA Area - Attribute Fulfillment code, result-code and error-code. Integer value: min. value 1; max. 8 digits.	xsd:string 5505	P
*/type	Identification of the message type. Alphanumeric entry: fixed length 3 characters.	xsd:string A02	P
*/trade-id	Identification of the order. Integer value: min. value 1; 18 digits max.	xsd:string 317871	V
*/version	Order version. Integer value: min. value 1; 3 digits max.	xsd:string 1	V
*/external-id	Order Id in the market participant's system. Integer value: min. value 1; 10 digits max.	xsd:string 325489	V
*/result-code	Extended report/warning/error number. It is a 6-digit alphanumeric string in the form M<mxxxx>, where: <ul style="list-style-type: none"> m - module code the result code is originating from: <ul style="list-style-type: none"> 7 – IDA 0 – Other unclassified and system messages xxxx – numerical identification reports/warnings/errors, see "code" 	xsd:string M75505	V

²⁶ Example:

A01	Value example
A05	Constant
{A01; A10}	List of possible constants

²⁷ Usage in messages: P = Mandatory item; V = Optional item

Element/Attribute	Description	Data type or example ²⁶	Usage in messages ²⁷
	attribute, list of error messages in IDA, see chapter 5.2.2.1 Errors/Reports for IDA Area - Attribute Fulfillment code, result-code and error-code Alphanumeric entry: fixed length of 6 characters,		

5.2.2.1. Errors/Reports for IDA Area - Attribute Fulfillment *code*, *result-code* and *error-code*

The chapter defines the list of warnings and error messages that can be expected in a message within the IDA communication scenarios, with the resolution of the communication scenario in which it may occur. The first table entry is the value that can be found in the *code* attribute of the *Reason* XML element in the RESPONSE message, the second table entry defines a text message pattern describing the given warning/error that can be found in the Reason XML element of the RESPONSE message.

Table 20 - Errors/reports for IDA area - code, result-code and error-code attribute fulfillment

Code	Description	Type ²⁸	Creation / Modification	Deletion	Query
1009	Non-existent order unit.	E	*		
1116	Locked participant cannot perform any operations on the electricity market.	E	*	*	
1123	For the %s1 message type, only the subscriber's EIC code is supported in the SenderIdentification entry.	E	*	*	*
1124	For the message type %s1, only the EAN code of the subscriber is supported in the SenderIdentification item.	E	*	*	*
2000	Auction %s has ended.	E	*		
2004	Maximum quantity of the ordering participant has been exceeded.	E	*		
2009	Order price is lower than the minimum allowable price in the system.	E	*		
2010	Order price is higher than the maximum allowable price in the system.	E	*		
2011	Hourly quantity ordered is lower than the minimum allowed in the system.	E	*		
2012	Hourly quantity ordered is higher than the maximum allowed in the system.	E	*		
2014	In buy order the prices in the segment must be strictly decreasing.	E	*		
2015	In sell order the prices in the segment must be strictly ascending.	E	*		
2019	The business day must be greater than the current day's date	E	*		
2020	There is no entry in the parameter table.	E	*		
2027	Order participant is not authorized for this type of bid.	E	*		
2030	A minimum income condition is not admissible for the second evaluation cycle.	E	*		
2038	The quantity is zero in all order hours.	E	*		
2200	Warranty limits are not met.	E	*	*	
2201	The product of quantity and price is zero in all order hours.	E	*		

²⁸ Type: E = Error message; I = Informative message; W = Warning

Code	Description	Type ²⁸	Creation / Modification	Deletion	Query
2260	Meets the guarantee: Bank Validation.	I	*		
2261	Meets the warranty: The warranty limits are almost exhausted.	E	*	*	
2262	SFVOT - %d error occurred while verifying guarantees.	E	*	*	
2264	SFVOT - Warranty limits are currently locked. Please try again later.	E	*	*	
2290	The warranty limits of the Super-Subject are not met.	E	*	*	
2309	In the case of modification of the order, the code and version of the order must be filled in.	E	*		
2310	Error in order header: invalid block order category.	E	*		
2312	In the case of a profile block order, there must be a fixed price in all hours of the block.	E	*		
2313	The minimum match rate must be in the range %s1 - 100.	E	*		
2314	Invalid exclusive group identifier.	E	*		
2315	The minimum level of the agreed quantity is allowed only in the case of a profile block order.	E	*		
2316	Exclusive group is only allowed in case of profile block order.	E	*		
2317	Deletion of linked block orders must proceed from the lowest level.	E		*	
2318	Order does not meet the conditions for modification.	E	*		
2319	Exclusive group identification must be unique within the day of delivery.	E	*		
2322	Only 1 block can be specified for PBO orders.	E	*		
2323	Incorrect identification of parent profile block order.	E	*		
2324	Only a PBO order can have a parent profile block order defined.	E	*		
2325	An exclusive group can only contain orders for one day of delivery.	E	*		
2328	PBO order can be part of a maximum of one block order group.	E	*		
2363	Maximum level of linked profile block order exceeded, limit is %s.	E	*		
2364	Maximum number of exclusive subscriber groups has been exceeded for the given day of delivery, the limit is %s.	E	*		
2365	Maximum number of PBO orders in one exclusive group has been exceeded, the limit is %s.	E	*		
2366	Maximum number of PBO linked order families per market participant has been exceeded, the limit is %s.	E	*		
2367	Maximum number of linked PBO orders in one family has been exceeded, the limit is %s.	E	*		
2373	Participant is not a valid settlement entity.	E	*		
2374	If modifying the order, the exclusive group cannot be changed.	E	*		
2501	Time will change on Sunday.	I	*		
2502	Today is a time change.	I	*		
2532	Order %s1 version %s2 has already been deleted and cannot be deleted again.	E	*		
2536	Your user rights are insufficient to complete this operation.	E	*	*	
2538	Unable to load order for subscriber %s	E	*		
2604	Illegal quantity value.	E	*		
2605	Invalid prize value.	E	*		
2638	Order is not eligible for deletion.	E	*		

Code	Description	Type ²⁸	Creation / Modification	Deletion	Query
2641	Participant %s is not a valid settlement subject (from %d1 to %d2).	E	*	*	
2642	Participant is not authorized to participate in IDA (from %d1 to %d2).	E	*	*	
2645	Error in order header: order block identification is required.	E	*		
2646	Error in order header: invalid order segment identifier.	E	*		
2648	Participant is not eligible to participate in IDA.	E	*	*	
2649	Error in order header: settlement currency code is required.	E	*		
2650	Error in order header: invalid settlement currency code.	E	*		
2663	Auction %s is not open for orders.	E	*		
2665	Order Rejected: contains the hours in which the state of emergency was declared.	E	*		
2920	Order must not contain empty segments	E	*		
2923	The action was completed successfully.	I	*		
2924	Request %s is waiting for FS check, check the request queue.	I	*		
2929	No activity or default currency is set for the day of delivery!	E	*		
2941	No participant currency found. Return code:	E	*		
2948	Error in order header: invalid order market type.	E	*		
2950	Error at hour %d: price must not be specified.	E	*		
3015	The user does not have the necessary permissions to perform this operation.	E	*	*	
3029	Participant %s is not registered as a market participant.	E	*	*	
3122	User %s does not exist.	E	*	*	*
3165	Unexpected deletion type.	E	*		
3183	Wrong comment.	E	*		
3204	The data contains illegal characters (ASCII-%s).	E	*		
3570	Syntax error when validating order segments.	E	*		
3585	Error in order detail: zero price not allowed.	E	*		
3700	No detail has been entered for this order.	E	*		
3943	Failed system IDA deletion of order %s1 for delivery day: %s2 and auction: %s3	E	*		
3945	Request canceled at CS	E	*		
4018	Error in order header: incorrect number of items.	E	*	*	
4019	Error in order header: participant is mandatory information.	E	*		
4023	Error in order header: invalid date.	E	*		
4024	Error in order header: order class is mandatory.	E	*		
4025	Error in order header: invalid order class.	E	*		
4029	Error in order detail: order period is mandatory.	E	*		
4030	Error in order detail: invalid order period.	E	*		
4031	Error in period %d: electricity is required.	E	*		
4033	Error in period %d: price is required.	E	*		
4039	Invalid order detail.	E	*		
4043	Data not found in processing table.	E	*	*	*
4044	Error in order header: order code is mandatory.	E	*		

Code	Description	Type ²⁸	Creation / Modification	Deletion	Query
4046	Error in order header: order version is mandatory.	E	*		
4050	Error reading detail for email.	E	*	*	*
4051	Invalid operation type.	E	*	*	
4063	Order not found.	E	*	*	
4066	Another user is working with the order, please try again later.	E	*	*	
4077	Order is not eligible for deletion.	E	*		
4079	Order can only be deleted by owner of the order only.	E	*		
4118	Invalid order header.	E	*		
4131	Error in menu order: invalid %d. header item. %C	E	*	*	
5003	Incorrect number of separators.	E	*	*	*
5005	System error: %s	E	*	*	*
5007	Order with code %d1 and version %d2 has been loaded as invalid.	W	*		
5011	Error occurred while calling API functions. Error code = %s.	E	*	*	*
5019	Sender and owner of the data are not the same participant.	E	*	*	*
5020	Header error: "%s" is a required entry.	E	*	*	*
5021	Error in detail: "%s" is a required entry.	E	*	*	*
5022	Error in the header: order code is missing.	E	*		
5023	Error in the header: order version is missing.	E	*		
5024	Error in the header: code and version of the order or the date are missing.	E	*		
5025	EAN/RMP conversion error. Non-existent EAN of participant (%s).	E	*	*	*
5026	EAN/RMP conversion error. Non-existent sender EAN (%s).	E	*	*	*
5027	RMP/EAN conversion error. Non-existent RMP of participant (%s).	E	*	*	*
5028	Metadata error: '%s' is required entry.	E	*	*	*
5500	Order was created with code %d1 and version %d2.	I	*		
5503	Order with code %d1 and version %d2 has been deleted.	I		*	
5504	Query executed. Data found.	I			*
5505	Query executed. No data found.	I			*
5528	Order was deleted by the market operator. ²⁹	I		*	
5537	The order was deleted by the system (SFVOT).	T		*	
5778	A parent PBO can be part of at most one group of block orders.	E	*		
5824	It is not permitted to submit standard orders for the selected delivery date.	E	*		
5825	It is not permitted to submit profile block orders for the selected delivery date.	E	*		
5826	It is not permitted to submit profile block orders with exclusive group for the selected delivery date.	E	*		
5827	It is not permitted to submit linked profile block orders for the selected delivery date.	E	*		

²⁹ In case of deletion of all valid orders due to a change in validity

5.2.2.2. Mass IDA messages

Mass messages to IDA trading participants are sent in specific situations during the IDA. These are the following messages (identified by message-code):

Table 21 - Mass IDA messages

Message-code	Message
804	Postponement of closing date for the opening of receipt of IDA orders
805	Postponement of deadline for the end of receiving IDA orders
806	Delay in publication of IDA results
807	Deletion of auction
808	Capacity data for IDA
	Modification of capacity data for IDA
809	Notice of change/postponement of deadline
810	Publication of IDA results

5.2.3. ISOTEREQ

Table 22 - Content of IDA - ISOTEREQ data messages

Element/Attribute	Description	Data type or example ³⁰	Usage in messages ³¹	
			834	947
ISOTEREQ				
/Standard Message Header	A description of the standard header can be found in chapter 3.1.1 Standard OTE message header format	{/message-code=834 custom order data request; */message-code=947 marginal cost demand and quantity IDA}	P	P
Trade				
*/trade-day	Delivery day in yyyy-mm-dd format	xsd:date 2020-06-18	V	P
*/trade-session	Identification auction of given delivery day <ul style="list-style-type: none"> IDA1 – First IDA Auction IDA2 – Second IDA auction IDA3 – Third IDA auction 	xsd:string {IDA1; IDA2; IDA3}	V	V
*/id	Order code. Integer value: min. value 1; 18 digits max.	xsd:string 76638	V	N/A
*/version	Order version. Integer value: max. 3 digits.	xsd:string 2	V	N/A

The request for orders (834) can be asked in two variants:

³⁰ Example:

A01	Value example
A05	Constant
{A01; A10}	List of possible constants

³¹ Usage in messages: P = Mandatory item; V = Optional Item; N/A = Unused item

Table 23 - Inquiry about a specific order:

Element/Attribute	Usage in messages
*/id	Mandatory item
*/version	Mandatory item

Table 24 - Query on all orders for the specified delivery day (and possibly the auction):

Element/Attribute	Usage in messages
*/trade-day	Mandatory item
*/trade-session	Mandatory item

If the items of both variants are filled in the request, **variant No. 1 always takes precedence.**

5.2.4. StatusRequest_MarketDocument

Query for IDA capacity data

Table 25 - StatusRequest_MarketDocument (v4.1)

Element/Attribute	Description	Data type and example ³²	Usage in message s ³³
<i>StatusRequest_MarketDocument (v4.1)</i>			
mRID	The unique identifier of the StatusRequest document generated by the source system of the message sender.	xs:string(60) 20090501_A13_8591824010402_1	P
type	Message type of the document the status request sender is asking for . <ul style="list-style-type: none"> A31 – Capacity data (Agreed Capacity) 	string(3) A31	P
sender_MarketParticipant.mRID	Identification of the status request sender (EIC or EAN code)	xs:string (16) 11XJKL-CZ-----1 or 8591824099902	P
sender_MarketParticipant.mRID.codingScheme	Coding scheme of sender identification: <ul style="list-style-type: none"> A01 – for EIC code (Energy Identification Coding Scheme) A10 – for EAN code (European Article Number) 	string(3) {A01; A10}	P
sender_MarketParticipant.marketRole.type	Role of status request sender: <ul style="list-style-type: none"> A01 – Participant (Trade responsible party) 	string(3) A01	P
receiver_MarketParticipant.mRID	Identification of status request receiver (EIC or EAN code)	xs:string(16) 27XOTE-CZECHREPB or 8591824000007	P
receiver_MarketParticipant.mRID.codingScheme	Coding scheme of receiver identification: <ul style="list-style-type: none"> A01 – for EIC code (Energy Identification Coding Scheme) A10 – for EAN code (European Article Number) 	string(3) {A01; A10}	P

³² Example:

A01	Value example
A05	Constant
{A01; A10}	List of possible constants

³³ Usage in messages: P = Mandatory item

Element/Attribute	Description	Data type and example ³²	Usage in message _s ³³
receiver_MarketParticipant.marketRole.type	Role of status request receiver: <ul style="list-style-type: none"> A11 – Market operator 	string(3) A11	P
createdDateTime	Document creation timestamp. According to ISO 8601, in UTC format: YYYY-MM-DDTHH:MM:SSZ	xs:dateTime 009-04-30T07:10:30Z	P
<i>AttributeInstanceComponent</i>		<i>Structure</i>	
attribute	Name of searching attribute to specify domain identification of being requested document (case sensitive).	string domain.mRID	P
attributeValue	49Y000000000000S	string 49Y000000000000S	P
attributeValue.codingScheme	Coding scheme of domain identification of being requested document: <ul style="list-style-type: none"> A01 – for EIC code (Energy Identification Coding Scheme) 	string(3) A01	P
<i>AttributeInstanceComponent</i>		<i>Structure</i>	
attribute	Name of searching attribute to specify the required time interval of being requested document (case sensitive).	string requestedTimeInterval	P
attributeValue	Specification of the required time interval according to ISO 8601, in UTC format: YYYY-MM-DDThh:00Z/YYYY-MM-DD+1Thh:00Z The time interval is only possible within one day.	string 2009-04-30T22:00Z/2009-05-01T22:00Z	P
<i>AttributeInstanceComponent</i>		<i>Structure</i>	
attribute	Name of searching attribute to specify IDA auction the requested capacity data are to be provided for.	string auction.mRID	V
attributeValue	Specification of IDA auction the requested capacity data are to be provided for: <ul style="list-style-type: none"> IDA1 – First IDA auction IDA2 – Second IDA auction IDA3 – Third IDA auction 	string {IDA1, IDA2, IDA3}	

5.2.5. Capacity_OTEMarketDocument

Response to request for IDA capacity data.

Table 26 - CapacityDocument_OTEMarketDocument (CIM like CapacityDocument_MarketDocument v8.1)

Element/Attribute	Description	Data type and example ³⁴	Usage in message _s ³⁵
<i>CapacityDocument_OTEMarketDocument</i>			
mRID	A unique message identifier of Capacity_OTEMarketDocument.	xs:string(60) IDA3_F2CZC_CIP_OTE_20220311001	P
revisionNumber	Document version <1;999>	xs:string [1-9]([0-9]){0,2} 1	P

³⁴ Example:

A01	<i>Value example</i>
A05	<i>Constant</i>
{A01; A10}	<i>List of possible constants</i>

³⁵ Usage in messages: P = Mandatory item

Element/Attribute	Description	Data type and example ³⁴	Usage in message ³⁵
type	Message type: <ul style="list-style-type: none"> A31 – Capacity data (Agreed Capacity) 	string(3) A31	P
process.processType	Process type: <ul style="list-style-type: none"> A07 - Capacity allocation 	string(3) A07	P
sender_MarketParticipant.mRID	Identification of the initial capacity data provider (IDA TSOs): <ul style="list-style-type: none"> 27V-IDA-SG-DATA4 	xs:string(16) 27V-IDA-SG-DATA4	P
sender_MarketParticipant.mRID.codingScheme	Coding scheme of identification of the initial capacity data provider: <ul style="list-style-type: none"> A01 – EIC code (Energy Identification Coding Scheme) 	String(3) A01	P
sender_MarketParticipant.marketRole.type	Sender's Role: <ul style="list-style-type: none"> A36 – Capacity Coordinator 	string(3) A36	P
receiver_MarketParticipant.mRID	Identification of initial capacity data receiver (EIC code of the OTE recipient): <ul style="list-style-type: none"> 27XOTE-CZECHREPB 	xs:string(16) 27XOTE-CZECHREPB	P
receiver_MarketParticipant.mRID.codingScheme	Coding scheme of identification of initial capacity data receiver: <ul style="list-style-type: none"> A01 – EIC code (Energy Identification Coding Scheme) 	string(3) A01	P
receiver_MarketParticipant.marketRole.type	Receiver's role: <ul style="list-style-type: none"> A11 – Market operator 	string(3) A11	P
createdDateTime	Document creation timestamp. According to ISO 8601, in UTC format: YYYY-MM-DDTHH:MM:SSZ	xs:dateTime 2022-03-10T10:42:07Z	P
received_MarketDocument.mRID	The unique identifier of the document to which the response is returned.	xs:string(60) 20190501_A31_8591824010402_1	P
period.timeInterval³⁶	Structure		
start	Beginning of time interval for which capacity data are provided at ISO 8601, in UTC format: YYYY-MM-DDThh:00Z For <i>auction.mRID</i> = {IDA3} time of beginning of interval equals to 12:00AM in UTC format.	xs:string(17) 2022-03-10T23:00Z (for IDA1, IDA2) or 2022-03-11T11:00Z (for IDA3)	P
end	End of time interval for which capacity data are provided at ISO 8601, in UTC format: YYYY-MM-DDThh:00Z	xs:string(17) 2022-03-11T23:00Z	P
domain.mRID	domain.mRID	Domain code: 10Y1001C--00059P	P
domain.mRID.codingScheme	Coding scheme of the domain code: <ul style="list-style-type: none"> A01 – EIC code (Energy Identification Coding Scheme) 	string(3) A01	P
CapacityTimeSeries	Structure (frequency: 0..n)		
mRID	A unique time series identifier generated by the sender's source system.	xs:string(60) 1	P
businessType	Business type: <ul style="list-style-type: none"> A25 - General Capacity Information 	string(3) A25	P
product	8716867000016 - ActivePower	string(13) 8716867000016	P
in_Domain.mRID	Identification of import delivery area.	xs:string(18) 10YAT-APG-----L	P
in_Domain.mRID.codingScheme	Coding scheme of identification of import delivery area:	string(3) A01	P

³⁶ The time interval (start-end) is within one day.

Element/Attribute		Description	Data type and example ³⁴	Usage in message ³⁵
		<ul style="list-style-type: none"> A01 – EIC code (Energy Identification Coding Scheme) 		
	out_Domain.mRID	Identification of export delivery area.	xs:string(18) 10YCB-GERMANY--8	P
	out_Domain.mRID.codingScheme	Coding scheme of identification of export delivery area: <ul style="list-style-type: none"> A01 – EIC code (Energy Identification Coding Scheme) 	string(3) A01	P
	measurement_Unit.name	Unit of quantity <ul style="list-style-type: none"> MAW (Mega watt) 	string(3) MAW	P
	auction.mRID	IDA auction specification: <ul style="list-style-type: none"> IDA1 – First IDA auction IDA2 – Second IDA auction IDA3 – Third IDA auction 	xs:string(60) {IDA1, IDA2, IDA3}	P
	<i>Period</i>	<i>Structure</i>		
	<i>timeInterval</i>	<i>Structure</i>		
	start	Beginning of time interval for which capacity data are provided at ISO 8601, in UTC format: YYYY-MM-DDThh:00Z Equals to value of <i>period.timeInterval.start</i>	xs:string(17) 2022-03-10T23:00Z (for IDA1, IDA2) or 2022-03-11T11:00Z (for IDA3)	P
	end	End of time interval for which capacity data are provided at ISO 8601, in UTC format: YYYY-MM-DDThh:00Z Equals to value of <i>period.timeInterval.start</i>	xs:string(17) 2022-03-11T23:00Z	P
	resolution	Period resolution: <ul style="list-style-type: none"> PT60M - hourly interval PT15M – 15 minutes interval 	xs:duration {PT60M; PT15M}	P
	<i>Interval</i>	<i>Structure (1..n)</i>		
	position	A sequence starting at 1. There are as many intervals as can fit into a given time interval for a given resolution $[(timeInterval.end - timeInterval.start)/resolution]$. In case of IDA1 and IDA2: <ul style="list-style-type: none"> For 15 min. resolution 1..96 (92/100 – on transition days) intervals For 60 min. resolution: 1..24 (23/25 - on transition days) intervals In case of IDA3: <ul style="list-style-type: none"> For 15 min. resolution 1..48 intervals For 60 min. resolution: 1..12 intervals 	xs:integer; <1;999999> 23	P
	quantity	Volume quantity in a given measurement unit	xs:decimal 4820	P

5.2.6. Acknowledgement_MarketDocument

Acknowledgment of receipt of request for IDA capacity data.

Table 27 - Acknowledgement_MarketDocument (v8.1)

Element/Attribute	Description	Data type and example ³⁷	Usage in message _s ³⁸
Acknowledgement_MarketDocument (v8.1)			
mRID	Unique identifier of the Acknowledgment document generated by the source system of the sender.	xs:string(60) 20190501_A13_8591824000007_1	P
createdDateTime	Document creation timestamp. According to ISO 8601, in UTC format: YYYY-MM-DDTHH:MM:SSZ	xs:dateTime 2019-05-01T07:10:30Z	P
sender_MarketParticipant.mRID	Identification of the sender of the document (EIC or EAN code)	xs:string(16) 27XOTE-CZECHREPB or 8591824000007	P
sender_MarketParticipant.mRID.codingScheme	Coding scheme of identification of the sender: <ul style="list-style-type: none"> A01 - Energy Identification Coding Scheme (EIC) A10 – for EAN 	string(3) {A01; A10}	P
sender_MarketParticipant.marketRole.type	Sender's role: <ul style="list-style-type: none"> A11 – Market operator 	string(3) A11	P
receiver_MarketParticipant.mRID	Receiver identification (EIC or EAN code)	xs:string(16) 11XJKL-CZ-----1 or 8591824099902	P
receiver_MarketParticipant.mRID.codingScheme	Coding scheme of receiver identification: <ul style="list-style-type: none"> A01 - Energy Identification Coding Scheme (EIC) A10 – for EAN 	string(3) {A01; A10}	P
receiver_MarketParticipant.marketRole.type	Receiver's role: <ul style="list-style-type: none"> A01 – Participant (Trade responsible party) 	string(3) {A01}	P
received_MarketDocument.mRID	The unique identifier of the request document to which the response is returned.	xs:string(60) 20190501_A13_8591824010402_1	P
received_MarketDocument.type	Message type of requested document within status request to which the answer is returned: A31 – Capacity data (Agreed Capacity)	string(3) {A31}	P
received_MarketDocument.createdDateTime	The timestamp of the creation of the data request document to which the response is provided. According to ISO 8601, in UTC format: YYYY-MM-DDTHH:MM:SSZ	xs:dateTime 2019-05-01T07:11:05Z	P
Reason		Structure (frequency: 1..n)	
code	Return codes (according to the CIM standard) identifying errors at the document header level.	string(3) A94	P
text	Detailed description of the error.	xs:string(512) Invalid message type.	P

³⁷ Example:

A01	Value example
A05	Constant
{A01; A10}	List of possible constants

³⁸ Usage in messages: P = Mandatory item; N/A = Not used

5.2.6.1. Acknowledgement_MarketDocument (v8.1) – return codes in the Reason element for the IDA area

Return codes and their detailed description in the Acknowledgment_MarketDocument (EAD) for the IDA area:

Table 28 - Acknowledgement_MarketDocument (v8.1) – Return codes of the Reason.code, Reason.text attributes for the IDA area

code	text
999	System error.
A02	Error when validating XML file. %s
A04	Invalid time interval.
A51	Message identification or version conflict.
A53	Invalid receiver role.
A53	Invalid receiver coding scheme.
A53	Invalid receiver identification.
A69	Attribute %s is mandatory.
A78	Invalid sender role.
A78	Invalid sender coding scheme.
A78	Invalid sender identification.
A80	Invalid domain.
A94	Invalid requested document type.
A94	Duplicate attributes specified.
A94	Data capacity are not available, delivery date is not yet open for trading.
A94	Invalid auction identification

6. Registration of Realization Diagrams (RRD)

6.1. RRD Communication Scenarios

The schematic depiction of communication scenarios does not specify a specific real-world call to the respective web service and does not address specific differences in Server-Server and Client-Server communication, for the sake of simplicity it only shows in which message format the MP transmits the given request and which message format is provided as a response.

The methods of communication for individual RRD communication scenarios are summarized in the following table, a detailed description of the mentioned methods of communication and relevant web services is given in [1]

Table 29 – Communication methods for RRD communication scenarios

Communication scenario	Method of communication
RD (chapter 6.1.1)	Asynchronous communication scenario
RD (chapter 6.1.2)	Asynchronous communication scenario
RD (chapter 6.1.3)	Asynchronous communication scenario
RD Mass Messages (chapter 6.1.4)	Asynchronous communication scenario

6.1.1. RD Entry

The *Schedule_MarketDocument* message entry allows creation of a new, or replacement/cancellation of existing realization diagram (RD). One RD entry message may contain only one schedule (with one buy or sell, or two buy and sell time series). Validation process executed upon message receipt will notify MP about the result of the validation:

- message *Acknowledgement_MarketDocument*
 - Negative response (error code \neq A01) – in case the message validation is not successful, consequently the diagram in question is not created.
 - Positive response (error code = A01) - in case of successful message validation the diagram in question is processed.

If the RD of the counterparty is registered in the system, the matching process is started. As a result of the diagram matching process and its imbalance utilization, a *AnomalyReport_MarketDocument* or *Confirmation_MarketDocument* message is sent to MP:

- message *AnomalyReport_MarketDocument* (AR) is sent in case of discrepancies found during matching process or in case of successful matching but unsuccessful subsequent financial security (FS) check. Trade position will not be created for MPs of not matched time series. The AR contains a description of the discrepancies for one or two timeseries.
- message *Confirmation_MarketDocument* (CR) is sent in case of successful matching and successful subsequent execution of financial security check; it is a confirmation of the matched values. A trading position will be created for MPs of confirmed time series. The CR contains details of one or two matched time series.

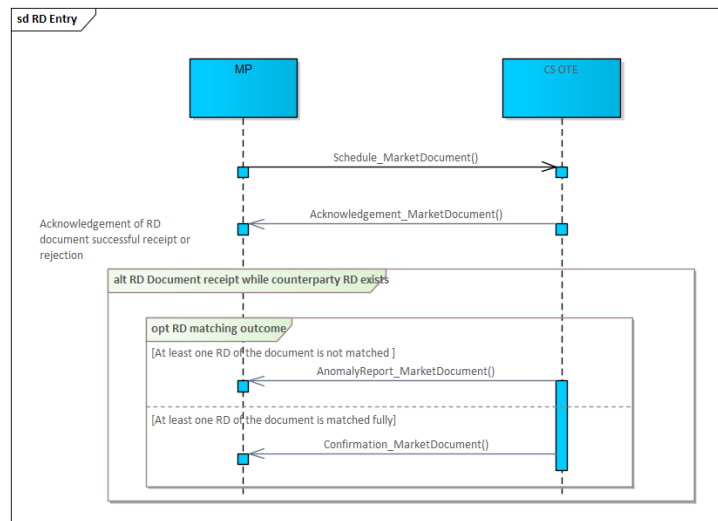

Figure 11 - Communication scenario - Creating RD

6.1.2. RD Status Request

The *StatusRequest_MarketDocument* (SR) request allows you to find out the status of a certain implementation diagram (RD). After receiving the request, it will be validated. In case of unsuccessful validation or if the RD cannot be found according to the specified criteria or the specified criteria are not unambiguous (the criteria match the RD of more than one document with the RD), the appropriate error (negative response, where the error code \diamond A01) is returned in the message *Acknowledgement_MarketDocument*.

In case of successful validation, *StatusRequest_MarketDocument* is returned:

- The *AnomalyReport_MarketDocument* (AR), which is sent in the event of the existence of at least one unpaired RD time series due to mismatches within the framework of matching or due to insufficient financial security (FS) or in the absence of a counterparty time series. The AR contains a description of the discrepancies
- The *Confirmation_MarketDocument* (CR), which is sent if there is at least one successfully matched and funded RD time series; it is a confirmation of the agreed values.

If any of the time series of the requested RD is unpaired (e.g. due to insufficient financial security) even if the counterparty's RD is recorded, the system will try to match the RD before sending the AR/CR response, if this option is enabled in the system (currently this option disabled).

AR³⁹ will result in one or two time series.

CR will result in one or two time series.

³⁹ Generally speaking, the system generates an AnomalyReport provided that:

- at least one anomalous RD is nonzero, or
- if at least one zero RD is a nullifying RD that nullifies the previous non-zero position

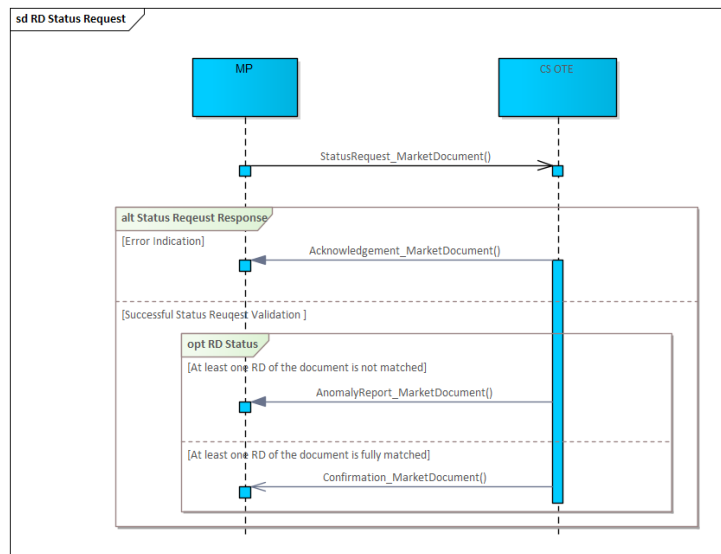

Figure 12 - Communication scenario - Determining the status of the RD

Note: If a domestic RD (businessType="A02") was registered in the system, within which a state of emergency was declared for one of the periods, a zero amount will be returned in AR/CR for this period. For foreign RD (businessType="A06"), the quantity in emergency periods will be provided as it was recorded in the system regardless of emergency periods.

6.1.3. RD Matching Outcome

This communication scenario occurs when the pairing process of an already registered RD is carried out additionally later after the RD has been registered (the RD pairing does not occur immediately after the RD has been registered) for example due to:

- Reaction to the RD records of the counterparty
- Final pairing of registered but unpaired RD (e.g. due to insufficient financial security of one of the RD parties)

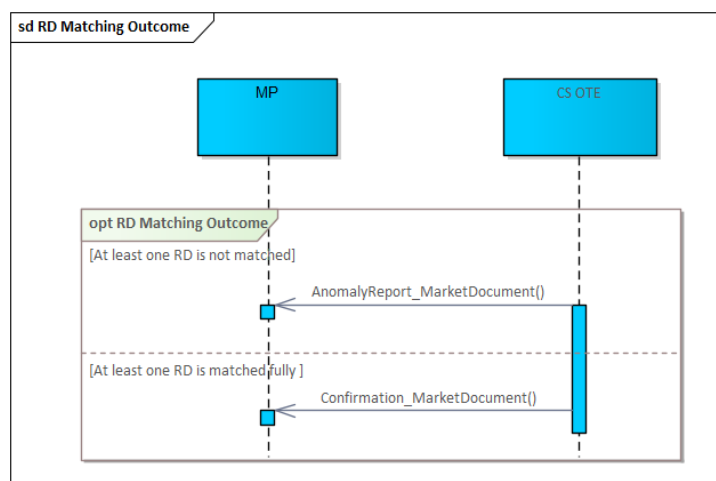

Figure 13 - Communication Scenario - RD Matching Outcome

6.1.4. RD Mass Messages

The RRD module sends following mass messages to imbalance responsible parties:

- postponement of RRD gate closure time (identified by the message code – message-code=981)
- RRD aggregations (identified by message code – message-code=992)

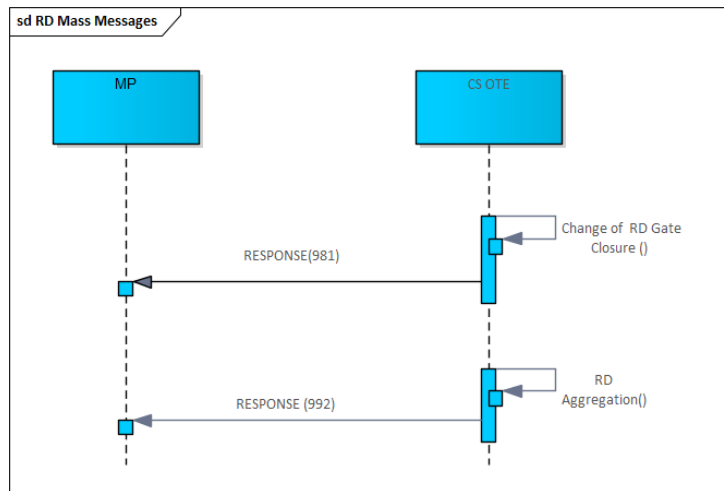

Figure 14 - Communication Scenario - RD Mass Messages

6.2. Content of RRD Data Messages

The chapter describes content of data messages used in the framework of communication scenarios within RRD towards MP.

6.2.1. Schedule_MarketDocument

The Schedule_MarketDocument message is used for RDs Entry (RD Creation, Modification and Cancelation).

Table 30 - Schedule_MarketDocument (v5.2)

Element/Attribute	Description	Data type and example ⁴⁰	Usage in message ⁴¹
<i>Schedule_MarketDocument (v5.2)</i>			
mRID	Unique identifier of the schedule document generated by the source system of the message sender.	xs:string(60) 20240311_A01_8591824099902_323	P

⁴⁰ Example:

A01	<i>Value example</i>
A05	<i>Constant</i>
{A01; A10}	<i>List of possible constants</i>

⁴¹ Usage in messages: P = Mandatory item; V = Optional Item; PP = Conditional Item; N/A = Unused item

Element/Attribute	Description	Data type and example ⁴⁰	Usage in messages ⁴¹
revisionNumber	Version of the schedule document generated by the source system of the message sender. <1;999>	xs:string [1-9]([0-9]){0,2}1	P
type	Message type: <ul style="list-style-type: none"> A01 - Balance responsible schedule - schedule type intermediate (valid for all domestic RDs and for foreign RDs, which are not A09) A09 - Finalized schedule - (only for foreign RDs) 	string(3) {A01; A09}	P
process.processType	Process type <ul style="list-style-type: none"> A01 – Day-ahead A02 – Intra day incremental 	string(3) {A01; A02}	P
process.classificationType	<ul style="list-style-type: none"> A01 - Detail type 	string(3) A01	P
sender_MarketParticipant.mRID	Sender identification (EAN code)	xs:string(16) 8591824099902	P
sender_MarketParticipant.mRID.codingScheme	Sender identification coding scheme: <ul style="list-style-type: none"> A10 – EAN (European Article Number) 	string(3) A10	P
sender_MarketParticipant.marketRole.type	Sender's role: <ul style="list-style-type: none"> A01 – Market Participant (Trade responsible party) A04 – ČEPS (System operator) A11 – PXE (Market Operator) 	string(3) {A01; A04; A11}	P
receiver_MarketParticipant.mRID	Receiver identification (EAN code) <ul style="list-style-type: none"> OTE identification 	xs:string(16) 8591824000007	P
receiver_MarketParticipant.mRID.codingScheme	Receiver identification coding scheme: <ul style="list-style-type: none"> A10 – EAN (European Article Number) 	string(3) A10	P
receiver_MarketParticipant.marketRole.type	Receiver's role: <ul style="list-style-type: none"> A05 – OTE (Imbalance settlement responsible) 	string(3) A05	P
createdDateTime	Time stamp of document creation. ISO 8601 UTC format: YYYY-MM-DDTHH:MM:SSZ	xs:dateTime 2024-03-11T10:42:07Z	P
<i>schedule_Time_Period.timeInterval⁴²</i>	<i>Structure</i>		
Start	Beginning of time interval of given delivery day at ISO 8601 UTC format: YYYY-MM-DDThh:00Z	xs:string(17) 2022-03-10T23:00Z	P
end	End of time interval of given delivery day at ISO 8601 UTC format: YYYY-MM-DDThh:00Z	xs:string(17) 2022-03-11T23:00Z	P
domain.mRID	Domain identification, EIC code: 10YCZ-CEPS-----N	xs:string(18) 10YCZ-CEPS-----N	P
domain.mRID.codingScheme	Domain identification coding scheme: <ul style="list-style-type: none"> A01 – EIC code (Energy Identification Coding Scheme) 	string(3) A01	P
subject_MarketParticipant.mRID	Identification of market participant the schedule is sent on behalf of (EAN code). <ul style="list-style-type: none"> For domestic RDs sent by PXE the value is different to schedule sender identification, for domestic RD sent by market participant the value equals to schedule sender identification. For foreign RDs sent by system operator (ČEPS) the value is different to schedule sender identification 	xs:string(16) 8591824099902	P

Element/Attribute	Description	Data type and example ⁴⁰	Usage in messages ⁴¹
subject_MarketParticipant.codingScheme	Subject party identification coding scheme: <ul style="list-style-type: none"> A10 – EAN code (European Article Number) 	string(3) A10	P
subject_MarketParticipant.marketRole.type	Subject party role: <ul style="list-style-type: none"> A01 – Market Participant (Trade responsible party) 	string(3) A01	P
<i>matching_time_Period.timeInterval</i> ⁴³	<i>Structure</i>		
	Matching period: <ul style="list-style-type: none"> for day-ahead schedules (process.processType=A01) equals to schedule time interval (<i>schedule_time_Period.timeInterval</i>). for intraday schedules (process.processType=A02) equals to schedule time interval (<i>schedule_time_Period.timeInterval</i>). 		
Start	Beginning of matching period time interval at ISO 8601 UTC format: YYYY-MM-DDThh:00Z	xs:string(17) 2024-03-10T23:00Z	P
end	End of matching period time interval at ISO 8601 UTC format: YYYY-MM-DDThh:00Z	xs:string(17) 2024-03-11T23:00Z	P
<i>TimeSeries</i>	<i>Structure (frequency: 1..2)</i>		
mRID	Unique time series identifier generated by the source system of the sender.	Xs:string(60) TS_001	P
version	Version of time series generated by the source system of the sender.<1;999>	xs:string [1-9]([0-9]){0,2} 1	P
businessType	Time series business type: <ul style="list-style-type: none"> A02 – Internal trade (domestic RD provided by MPS or PXE) A06 – External trade without explicit capacity (foreign RD provided by CEPS). 	String(3) {A02; A06}	P
product	Product identification: <ul style="list-style-type: none"> 8716867000016 – ActivePower 	string(13) 8716867000016	P
objectAggregation	Aggregation level of time series values: <ul style="list-style-type: none"> A03 – Party 	string(3) A03	P
in_Domain.mRID	Identification of a delivery area into which the product is delivered.	Xs:string(18) 10Y CZ-CEPS-----N	P
in_Domain.mRID.codingScheme	Coding scheme of the identification of a delivery area into which the product is delivered: <ul style="list-style-type: none"> A01 – EIC code (Energy Identification Coding Scheme) 	string(3) A01	P
out_Domain.mRID	Identification of a delivery area from which the product is taken.	Xs:string(18) 10Y CZ-CEPS-----N	P
out_Domain.mRID.codingScheme	Coding scheme of the identification of a delivery area from which the product is taken: <ul style="list-style-type: none"> A01 – EIC code (Energy Identification Coding Scheme) 	string(3) A01	P
in_MarketParticipant.mRID	Identification of the buying participant (EAN code).	string(16) 8591824099902	P
in_MarketParticipant.mRID.codingScheme	Coding scheme of the identification of the buying participant: <ul style="list-style-type: none"> A10 – EAN code (European Article Number) 	string(3) A10	P

Element/Attribute	Description	Data type and example ⁴⁰	Usage in messages ⁴¹
out_MarketParticipant.mRID	Identification of the selling participant (EAN code).	string(16) 8591824099703	P
out_MarketParticipant.mRID.codingScheme	Coding scheme of the identification of the selling participant: <ul style="list-style-type: none"> A10 –EAN code (European Article Number) 	string(3) A10	P
measurement_Unit.name	Unit of time series values <ul style="list-style-type: none"> MAW (Mega watt) 	string(3) MAW	P
<i>Period</i>		<i>Structure</i>	
<i>timeInterval</i>		<i>Structure</i>	
start	Beginning of time interval of a given delivery day at ISO 8601 UTC format: YYYY-MM-DDThh:00Z Equals to <i>schedule_time_Period.timeInterval.start</i>	xs:string(17) 2024-03-10T23:00Z	P
end	End of time interval of a given delivery day at ISO 8601 UTC format: YYYY-MM-DD+1Thh:00Z Equals to <i>schedule_time_Period.timeInterval.end</i>	xs:string(17) 2024-03-11T23:00Z	P
resolution	Delivery period time interval: <ul style="list-style-type: none"> PT15M – 15 minutes delivery period PT60M – 60 minutes delivery period 	xs:duration {PT15M, PT60M}	P
<i>Point</i>		<i>Structure (1..n)</i>	
position	Sequence with a starting value of 1. There are as many points as many resolutions fit into the given time series interval (<i>timeInterval</i>). Usually it is: <ul style="list-style-type: none"> 1..96 (92/100 – in case of SCC/LCC days) points for 15min resolution 1..24 (23/25 – in case of SCC/LCC days) points for 60min resolution 	xs:integer; <1;999999> 23	P
quantity	Amount of energy for each interval with an accuracy of 3 decimal places (decimal places separator symbol is '.').	xs:decimal 4820	P

Acceptable combinations of values of some items for RD Entry:

Table 31 – Acceptable combinations of values of some items for RD Entry

Business Type	TimeSeries.businessType	Process Type	process.processType	Message type	type
Domestic RD	A02	Day ahead	A01	Intermediate	A01
Foreign RD	A06	Day ahead	A01	Intermediate	A01
				Final	A09
		Intraday	A02	Intermediate	A01
				Final	A09

6.2.2. Acknowledgement_MarketDocument

The Acknowledgment_document message is used to inform the sender about the result of the processing of the received document.

Table 32 – Acknowledgement_MarketDocument (v8.1)

Element/Attribute	Description	Data type and example ⁴⁴	Usage in messages ⁴⁵
Acknowledgement_MarketDocument (v8.1)			
mRID	Unique identifier of the Acknowledge document generated by the source system of the acknowledge message sender.	Xs:string(60) 20240311_A01_8591824000007_11	P
createdDateTime	Time stamp of document creation. ISO 8601 UTC format: YYYY-MM-DDTHH:MM:SSZ	xs:dateTime 2024-03-11T10:42:30Z	P
sender_MarketParticipant.mRID	Sender identification (EAN code): • OTE identification	xs:string(16) 8591824000007	P
sender_MarketParticipant.mRID.codingScheme	Sender identification coding scheme: • A10 – EAN (European Article Number)	string(3) A10	P
sender_MarketParticipant.marketRole.type	Sender's role: • A05 – OTE (Imbalance settlement responsible)	string(3) A05	P
receiver_MarketParticipant.mRID	Receiver identification (EAN code)	xs:string(16) 8591824099902	P
receiver_MarketParticipant.mRID.codingScheme	Receiver identification coding scheme: • A10 – EAN (European Article Number)	string(3) A10	P
receiver_MarketParticipant.marketRole.type	Receiver's role: • A01 – Market Participant (Trade Responsible Party) • A04 – ČEPS (System Operator) • A11 – PXE (Market Operator)	string(3) {A01; A04; A11}	P
received_MarketDocument.mRID	Unique identifier of a received document the acknowledgement is returned for.	xs:string(60) 20240311_A01_8591824099902_323	P
received_MarketDocument.revisionNumber	Version of a received document the acknowledgement is returned for. <1;999>	xs:string [1-9]([0-9]){0,2} 1	P
received_MarketDocument.type	Type of a received document the acknowledgement is returned for: • A01 - Balance responsible schedule - schedule type intermediate (valid for all domestic RDs and for foreign RDs, which are not A09) • A09 - Finalized schedule - (only for foreign RDs)	string(3) {A01; A09}	P
received_MarketDocument.createdDateTime	Creation time stamp of a received document the acknowledgement is returned for at ISO 8601 UTC format: YYYY-MM-DDTHH:MM:SSZ	xs:dateTime 2024-03-11T10:42:07Z	P
Rejected_TimeSeries		Structure (frequency: 0..n)	
mRID	Unique identifier of a time series of a received document the acknowledgement is returned for.	xs:string(60) 20230311_A01_8591824099902_1	P
version	Version of a time series of a received document the acknowledgement is returned for. <1;999>	xs:string [1-9]([0-9]){0,2} 1	P
Reason		Structure (frequency: 1..n)	
code	Reason code at the time series level of received document.	string(3) A94	P

⁴⁴ Example:

A01	Value example
A05	Constant
{A01; A10}	List of possible constants

⁴⁵ Usage in messages: P = Mandatory item; V = Optional Item; PP = Conditional Item; N/A = Unused item

Element/Attribute	Description	Data type and example ⁴⁴	Usage in message ^s ₄₅
	<ul style="list-style-type: none"> List of reason codes – see chapter 6.2.6 Return codes in the Reason element for the RRD area 		
text	Text clarifying reason code meaning <ul style="list-style-type: none"> For reason texts see chapter 6.2.6 Return codes in the Reason element for the RRD area 	xs:string(512) Invalid message type.	P
<i>Reason</i>		<i>Structure (frequency: 1..n)</i>	
code	Reason code at the level of received document <ul style="list-style-type: none"> List of reason codes – see chapter 6.2.6 Return codes in the Reason element for the RRD area 	string(3) A94	P
text	Text clarifying reason code meaning <ul style="list-style-type: none"> For reason texts see chapter 6.2.6 Return codes in the Reason element for the RRD area 	xs:string(512) Invalid message type.	P

6.2.3. StatusRequest_MarketDocument

The StatusRequest_MarketDocument message is used to determine the status of the RD.

Table 33 - StatusRequest_MarketDocument (v4.1)

Element/Attribute	Description	Data type and example ⁴⁶	Usage in message ^s ₄₇
<i>StatusRequest_MarketDocument (v4.1)</i>			
mRID	Unique identifier of the status request document generated by the source system of the message sender.	xs:string(60) 20240311_8591824099902_555	P
type	Message type of the document the status request sender is asking for: <ul style="list-style-type: none"> A01 - Balance responsible schedule - schedule type intermediate (valid for all domestic RDs and for foreign RDs, which are not A09) A09 - Finalized schedule - (only for foreign RDs) 	string(3) {A01; A09}	P
sender_MarketParticipant.mRID	Sender identification (EAN code)	xs:string (16) 8591824099902	P
sender_MarketParticipant.mRID.codingScheme	Sender identification coding scheme: <ul style="list-style-type: none"> A10 – EAN (European Article Number) 	string(3) A10	P
sender_MarketParticipant.marketRole.type	Sender's role: <ul style="list-style-type: none"> A01 – Market Participant (Trade responsible party) A04 – ČEPS (System operator) A11 – PXE (Market Operator) 	string(3) {A01; A04; A11}	P
receiver_MarketParticipant.mRID	Receiver identification (EAN code) <ul style="list-style-type: none"> OTE identification 	xs:string(16) 8591824000007	P

⁴⁶ Example:

A01	<i>Value example</i>
A05	<i>Constant</i>
{A01; A10}	<i>List of possible constants</i>

⁴⁷ Usage in messages: P = Mandatory item; V = Optional Item; PP = Conditional Item; N/A = Unused item

Element/Attribute	Description	Data type and example ⁴⁶	Usage in messages ⁴⁷
receiver_MarketParticipant.mRID.codingScheme	Receiver identification coding scheme: <ul style="list-style-type: none"> A10 – EAN (European Article Number) 	string(3) A10	P
receiver_MarketParticipant.marketRole.type	Receiver's role: <ul style="list-style-type: none"> A05 – OTE (Imbalance settlement responsible) 	string(3) A05	P
createdDateTime	Time stamp of document creation. ISO 8601 UTC format: YYYY-MM-DDTHH:MM:SSZ	xs:dateTime 2024-03-11T10:42:30Z	P
<i>AttributeInstanceComponent</i>		<i>Structure</i>	
attribute	Name of searching attribute to specify time interval of a delivery day of being requested schedule (case sensitive).	string <i>requestedTimeInterval</i>	P
attributeValue	Specification of time interval of a given delivery day at ISO 8601 in UTC format: YYYY-MM-DDThh:00Z/YYYY-MM-DD+1Thh:00Z Time interval must always cover one whole calendar day.	string 2024-03-10T23:00Z/2024-03-11T23:00Z	
<i>AttributeInstanceComponent</i>		<i>Structure</i>	
Attribute	Name of searching attribute to specify a sender of being requested schedule (case sensitive).	string reqSender.mRID	see Table 34
attributeValue	Sender's identification of being requested schedule (EAN code)	string 8591824099902	
attributeValue.codingScheme	Sender's identification coding scheme of being requested schedule: <ul style="list-style-type: none"> A10 – EAN code (European Article Number) 	string(3) A10	
<i>AttributeInstanceComponent</i>		<i>Structure</i>	
attribute	Name of searching attribute to specify a sender's role of being requested schedule (case sensitive).	string reqSender.marketRole.type	see Table 34
attributeValue	Sender's role of being requested schedule: <ul style="list-style-type: none"> A01 – Market Participant (Trade responsible party) A04 – ČEPS (System operator) A11 – PXE (Market Operator) 	string(3) {A01; A04; A11}	
<i>AttributeInstanceComponent</i>		<i>Structure</i>	
attribute	Name of searching attribute to specify an identification of a market participant the being requested schedule was provided on behalf of (case sensitive).	string reqSubject_MarketParticipant.mRID	see Table 34
attributeValue	Identification of the market participant the being requested schedule was provided on behalf of (EAN code) <ul style="list-style-type: none"> For domestic RDs sent by PXE the value is different to schedule sender identification, for domestic RD sent by market participant the value equals to schedule sender identification. For foreign RDs sent by system operator (ČEPS) the value is different to schedule sender identification 	string 8591824099902	
attributeValue.codingScheme	Coding scheme of the market participant identification the being requested schedule was provided on behalf of: <ul style="list-style-type: none"> A10 – EAN code (European Article Number) 	string(3) A10	
<i>AttributeInstanceComponent</i>		<i>Structure</i>	
attribute	Name of searching attribute to specify a role of a market participant the being requested schedule was provided on behalf of (case sensitive).	string reqSubject_MarketParticipant.marketRole.type	see Table 34

Element/Attribute		Description	Data type and example ⁴⁶	Usage in messages ⁴⁷
	attributeValue	Role of a market participant the being requested schedule was provided on behalf of: <ul style="list-style-type: none"> A01 – Market Participant (Trade responsible party) 	string(3) A01	
<i>AttributeInstanceComponent</i>		<i>Structure</i>		
	attribute	Name of searching attribute to specify matching period interval of being requested schedule (case sensitive).	string reqMatchingPeriod	see Table 34
	attributeValue	Matching period interval of being requested schedule at ISO 8601, in UTC format: YYYY-MM-DDThh:00Z/YYYY-MM-DD+1Thh:00Z Time interval must always cover one whole calendar day.	string 2024-03-10T23:00Z/2024-03-11T23:00Z	
<i>AttributeInstanceComponent</i>		<i>Structure</i>		
	attribute	Name of searching attribute to specify process type of being requested schedule (case sensitive).	string reqProcessType	see Table 34
	attributeValue	Process type of being requested schedule : <ul style="list-style-type: none"> A01 – Day-ahead A02 – Intra day incremental A12 – Long Term⁴⁸ 	string(3) {A01; A02; A12}	
<i>AttributeInstanceComponent</i>		<i>Structure</i>		
	attribute	Name of searching attribute to specify business type of being requested schedule (case sensitive).	string reqBusinessType	see Table 34
	attributeValue	Business type of being requested schedule: <ul style="list-style-type: none"> A02 - Internal trade (for RDs provided by market participants or PXE) A06 - External trade without explicit capacity (for RDs provided by ĆEPS). 	string(3) {A02; A06}	
<i>AttributeInstanceComponent</i>		<i>Structure</i>		
	attribute	Name of searching attribute to specify an identification of counterparty of being requested schedule (case sensitive).	string reqCounterParty.mRID	see Table 34
	attributeValue	An identification of counterparty of being requested schedule (EAN code)	string 8591824099703	
	attributeValue.codingScheme	Coding scheme of an identification of counterparty of being requested schedule : <ul style="list-style-type: none"> A10 – pro EAN code (European Article Number) 	string(3) A10	
<i>AttributeInstanceComponent</i>		<i>Structure</i>		
	attribute	Name of searching attribute to specify a message identification of being requested schedule (case sensitive).	string req.mRID	see Table 34
	attributeValue	Message identification of being requested schedule	string 20240311_A01_8591824099902_323	
<i>AttributeInstanceComponent</i>		<i>Structure</i>		
	attribute	Name of searching attribute to specify a message version of being requested schedule (case sensitive).	string req.revisionNumber	see Table 34
	attributeValue	Version of being requested schedule <1;999>	string(3) 1	

The query for RD (StatusRequest_MarketDocument) can be made in two variants:

⁴⁸ The A12 value is supported only for querying historical long-term foreign schedules

- A - Query on RD without using ID and document version:
- B - Query on RD by ID and document version

If the items of both variants are filled in the request, variant B always takes precedence.

Table 34 – Two variants of the RD query

Element/Attribute	Usage in messages ⁴⁹				
	A – RDs Status Request without ID and Version specification				B - RDs Status Request by ID and Version (both domestic and foreign)
	MP's request for domestic RDs (send by MP/PXE)	MP's request for foreign RDs (send by ČEPS)	PXE request for domestic RDs	ČEPS's request for foreign RDs	
*/reqSender.mRID	P MP-A/PXE	P ČEPS	P PXE	P ČEPS	N/A
*/reqSender.marketRole.type	P {A01/A011}	P {A04}	P {A11}	P {A04}	N/A
*/reqSubject_MarketParticipant.mRID	P MP-A	P MP-A	P MP-A	P MP-A	N/A
*/reqSubject_MarketParticipant.marketRole.type	P {A01}	P {A01}	P {A01}	P {A01}	N/A
*/reqMatchingPeriod	V	V	V	V	N/A
*/ reqProcessType	P {A01 }	P {A01; A02; A12}	P {A01}	P {A01; A02; A12}	N/A
*/reqBusinessType	P {A02}	P {A06}	P {A02}	P {A06}	N/A
*/reqCounterParty.mRID	P MP-B/PXE	V ČEPS	V PXE	V ČEPS	N/A
*/req.mRID	N/A	N/A	N/A	N/A	P
*/req.revisionNumber	N/A	N/A	N/A	N/A	P

6.2.4. AnomalyReport_MarketDocument

The AnomalyReport_MarketDocument is used to inform the schedule sender about discrepancies within the provided RDs.

⁴⁹ Usage in messages: P = Mandatory item; V = Optional Item; PP = Conditional Item; N/A = Unused item

Example:

	<i>Value in line with Status Request item examples specification</i>
MP-A	<i>EAN code in line with Status Request item examples specification</i>
{A01; A10}	<i>List of possible constants</i>

Table 35 - AnomalyReport_MarketDocument (v5.3)

Element/Attribute	Description	Data type and example ⁵⁰	Usage in messages ⁵¹
<i>Anomaly_MarketDocument (v5.3)</i>			
mRID	Unique identifier of the Anomaly Report document generated by the source system of the message sender.	xs:string(60) 20240311_AR_8591824000007_111	P
createdDateTime	Time stamp of document creation. ISO 8601 UTC format: YYYY-MM-DDTHH:MM:SSZ	xs:dateTime 2024-03-11T10:42:30Z	P
sender_MarketParticipant.mRID	Sender identification (EAN code) • Identification OTE	xs:string(16) 8591824000007	P
sender_MarketParticipant.mRID.codingScheme	Sender identification coding scheme: • A10 – EAN (European Article Number)	string(3) A10	P
sender_MarketParticipant.marketRole.type	Sender's role: • A05 – OTE (Imbalance settlement responsible)	string(3) A05	P
receiver_MarketParticipant.mRID	Receiver identification (EAN code)	xs:string(16) 8591824099902	P
receiver_MarketParticipant.mRID.codingScheme	Receiver identification coding scheme: • A10 – EAN (European Article Number)	string(3) A10	P
receiver_MarketParticipant.marketRole.type	Receiver's role: • A01 – Market Participant (Trade responsible party) • A04 – ČEPS (System operator) • A11 – PXE (Market Operator)	string(3) {A01; A04; A11}	P
<i>schedule_Time_Period.timeInterval⁵²</i>	<i>Structure</i>		
start	Beginning of time interval of given delivery day at ISO 8601 UTC format: YYYY-MM-DDThh:00Z	xs:string(17) 2022-03-10T23:00Z	P
end	End of time interval of given delivery day at ISO 8601 UTC format: YYYY-MM-DDThh:00Z	xs:string(17) 2022-03-11T23:00Z	P
domain.mRID	Domain identification, EIC code: 10Y CZ-CEPS-----N	xs:string(18) 10Y CZ-CEPS-----N	P
domain.mRID.codingScheme	Domain identification coding scheme: • A01 – EIC code (Energy Identification Coding Scheme)	string(3) A01	P
process.processType	Process type of sender message • A01 – Day-ahead • A02 – Intra day incremental • A12 – LongTerm ⁵³	string(3) {A01; A02; A12}	P
Anomaly_MarketDocument	<i>Structure (frequency: 1..2)</i>		
marketParticipant.mRID	Sender's identification of initial schedule document the found being reported anomalies are related to (EAN code)	xs:string(16) 8591824099902	P
marketParticipant.mRID.codingScheme	Coding scheme of sender's identification of initial schedule document the found being reported anomalies are related to:	string(3) A10	P

⁵⁰ Example:

A01	<i>Value example</i>
A05	<i>Constant</i>
{A01; A10}	<i>List of possible constants</i>

⁵¹ Usage in messages: P = Mandatory item; V = Optional Item; PP = Conditional Item; N/A = Unused item⁵³ The A12 value is supported for querying historical long-term foreign charts

2026 OTE, a.s.

Date of revision:
25.05.2026Document name:
D1.4.4_EN_Format_messages_XML_DM-IDA-Sol-RRD-FS-CDS.docx

Element/Attribute		Description	Data type and example ⁵⁰	Usage in message ⁵¹
		<ul style="list-style-type: none"> A10 – EAN code (European Article Number) 		
	mRID	Unique identifier of initial schedule document the found being reported anomalies are related to	xs:string(60) 20230311_A01_8591824099902_1	P
	revisionNumber	Version of initial schedule document the found being reported anomalies are related to <1;999>	xs:string [1-9]([0-9]){0,2} 1	P
	<i>TimeSeries</i>	<i>Structure</i>		
	mRID	Unique time series identifier generated by the source system of the sender.	xs:string(60) TS_001	P
	version	Version of time series generated by the source system of the sender.<1;999>	xs:string [1-9]([0-9]){0,2} 1	P
	businessType	Time series business type: <ul style="list-style-type: none"> A02 - Internal trade (domestic RD provided by MPs or PXE) A06 - External trade without explicit capacity (foreign RD provided by ČEPS). 	string(3) {A02; A06}	P
	product	Product identification: <ul style="list-style-type: none"> 8716867000016 - ActivePower 	string(13) 8716867000016	P
	objectAggregation	Aggregation level of time series values: <ul style="list-style-type: none"> A03 - Party 	string(3) A03	P
	in_Domain.mRID	Identification of a delivery area into which the product is delivered.	xs:string(18) 10Y CZ-CEPS-----N	P
	in_Domain.mRID.codingScheme	Coding scheme of the identification of a delivery area into which the product is delivered: <ul style="list-style-type: none"> A01 – EIC code (Energy Identification Coding Scheme) 	string(3) A01	P
	out_Domain.mRID	Identification of a delivery area from which the product is taken.	xs:string(18) 10Y CZ-CEPS-----N	P
	out_Domain.mRID.codingScheme	Coding scheme of the identification of a delivery area from which the product is taken: <ul style="list-style-type: none"> A01 – EIC code (Energy Identification Coding Scheme) 	string(3) A01	P
	in_MarketParticipant.mRID	Identification of the buying participant (EAN code).	string(16) 8591824099902	P
	in_MarketParticipant.mRID.codingScheme	Coding scheme of identification of the buying participant: <ul style="list-style-type: none"> A10 – pro EAN code (European Article Number) 	string(3) A10	P
	out_MarketParticipant.mRID	Identification of the selling participant (EAN code).	string(16) 8591824099703	P
	out_MarketParticipant.mRID.codingScheme	Coding scheme of identification of the selling participant : <ul style="list-style-type: none"> A10 – EAN code (European Article Number) 	string(3) A10	P
	measurement_Unit.name	Unit of time series values <ul style="list-style-type: none"> MAW (Mega watt) 	string(3) MAW	P
	<i>Period</i>	<i>Structure</i>		
	<i>timeInterval</i>	<i>Structure</i>		
	start	Beginning of time interval of a given delivery day at ISO 8601, UTC format: YYYY-MM-DDThh:00Z Equals to <i>schedule_time_Period.timeInterval.start</i>	xs:string(17) 2024-03-10T23:00Z	P

Element/Attribute		Description	Data type and example ⁵⁰	Usage in message s ⁵¹
	end	End of time interval of a given delivery day at ISO 8601, UTC format: YYYY-MM-DD+1Thh:00Z Equals to <i>schedule_time_Period.timeInterval.end</i>	xs:string(17) 2024-03-11T23:00Z	P
	resolution	Delivery period time interval: <ul style="list-style-type: none"> PT15M – 15 minutes delivery period PT60M – 60 minutes delivery period 	xs:duration {PT15M, PT60M}	P
<i>Point</i>		<i>Structure (1..n)</i>		
	position	Sequence with a starting value of 1. There are as many points as many resolutions fit into the given time series interval (timeInterval). Usually it is: <ul style="list-style-type: none"> 1..96 (92/100 – in case of SCC/LCC days) points for 15min resolution 1..24 (23/25 – in case of SCC/LCC days) points for 60min resolution 	xs:integer; <1;999999> 23	P
	quantity	Amount of energy for each interval with an accuracy of 3 decimal places (positive value, decimal places separator symbol is '.').	xs:decimal 4820	P
<i>Reason</i>		<i>Structure (1..n)</i>		
	code	Reason code at the level of time series identifying the anomaly details <ul style="list-style-type: none"> List of reason codes – see chapter 6.2.6 Return codes in the Reason element for the RRD area 	string(3) A29	P
	text	Text clarifying reason code meaning <ul style="list-style-type: none"> For reason texts see chapter 6.2.6 Return codes in the Reason element for the RRD area 	xs:string(512) Counterpart time series quantity differences.	P

6.2.5. Confirmation_MarketDocument

The Confirmation_MarketDocument message is used to inform the schedule sender about the confirmed values of the specified RDs.

Table 36 - Confirmation_MarketDocument (v5.3)

Element/Attribute		Description	Data type and example ⁵⁴	Usage in message s ⁵⁵
<i>Confirmation_MarketDocument (v5.3)</i>				
	mRID	Unique identifier of the Confirmation document generated by the source system of the message sender.	xs:string(60) 20240311_CR_8591824000007_11 1	P
	type	Type of confirmed message: <ul style="list-style-type: none"> A01 - Balance responsible schedule - type of transfer is continuous (valid for all domestic RDs and for foreign RDs) 	string(3) {A01; A09}	P

⁵⁴ Example:

A01	<i>Value example</i>
A05	<i>Constant</i>
{A01; A10}	<i>List of possible constants</i>

⁵⁵ Usage in messages: P = Mandatory item; V = Optional Item; PP = Conditional Item; N/A = Unused item

Element/Attribute	Description	Data type and example ⁵⁴	Usage in message ⁵⁵
	<ul style="list-style-type: none"> A09 - Finalized schedule - transfer type is final (only for foreign RDs) 		
createdDateTime	Timestamp of document creation at ISO 8601, UTC format: YYYY-MM-DDTHH:MM:SSZ	xs:dateTime 2024-03-11T10:42:30Z	P
sender_MarketParticipant.mRID	Sender identification (EAN code) <ul style="list-style-type: none"> OTE identification 	xs:string(16) 8591824000007	P
sender_MarketParticipant.mRID.codingScheme	Sender identification coding scheme: <ul style="list-style-type: none"> A10 – EAN code (European Article Number) 	string(3) A10	P
sender_MarketParticipant.marketRole.type	Sender's role: <ul style="list-style-type: none"> A05 – OTE (Imbalance settlement responsible) 	string(3) A05	P
receiver_MarketParticipant.mRID	Receiver identification (EAN code)	xs:string(16) 8591824099902	P
receiver_MarketParticipant.mRID.codingScheme	Receiver identification coding scheme: <ul style="list-style-type: none"> A10 – EAN code (European Article Number) 	string(3) A10	P
receiver_MarketParticipant.marketRole.type	Receiver's role: <ul style="list-style-type: none"> A01 – Market Participant (Trade responsible party) A04 – ČEPS (System operator) A11 – PXE (Market Operator) 	string(3) {A01; A04; A11}	P
<i>schedule_Period.timeInterval⁵⁶</i>		<i>Structure</i>	
start	Beginning of time interval of a given delivery day confirmation document at ISO 8601, UTC format: YYYY-MM-DDThh:00Z	xs:string(17) 2022-03-10T23:00Z	P
end	End of time interval of a given delivery day confirmation document at ISO 8601, UTC format: YYYY-MM-DD+1Thh:00Z	xs:string(17) 2022-03-11T23:00Z	P
confirmed_MarketDocument.mRID	Unique identifier of being confirmed document.	xs:string(60) 20240311_A01_8591824099902_1	P
confirmed_MarketDocument.revisionNumber	Version of being confirmed document <1;999>	xs:string [1-9]([0-9]){0,2} 1	P
domain.mRID	Domain identification, EIC code: 10YCZ-CEPS-----N	xs:string(18) 10YCZ-CEPS-----N	P
domain.mRID.codingScheme	Coding scheme of domain identification: <ul style="list-style-type: none"> A01 – EIC code (Energy Identification Coding Scheme) 	string(3) A01	P
subject_MarketParticipant.mRID	Identification of the participant the being confirmed schedule was sent on behalf (EAN code). <ul style="list-style-type: none"> For domestic RDs entered by PXE the identification of the subject and sender is different, for domestic RDs entered by participants, the identification of the subject and sender is identical. For foreign RDs entered by ČEPS, the identification of the subject and the sender is different. 	xs:string(16) 8591824099902	P
subject_MarketParticipant.mRID.codingScheme	Coding scheme of identification of the participant the being confirmed schedule was sent on behalf: <ul style="list-style-type: none"> A10 – EAN code (European Article Number) 	string(3) A10	P

Element/Attribute	Description	Data type and example ⁵⁴	Usage in messages ⁵⁵
subject_MarketParticipant.marketRole.type	The role of the participant the being confirmed schedule was sent on behalf. <ul style="list-style-type: none"> A01 – Market participant (Trade responsible party) 	string(3) A01	P
process.processType	Confirmation message process type: <ul style="list-style-type: none"> A01 – Day-ahead A02 – Intra day incremental A12 – LongTerm⁵⁷ 	string(3) {A01; A02; A12}	P
Reason		Structure (1..n)	
code	Reason code (according CIM standard) at the document header level. <ul style="list-style-type: none"> List of reason codes – see chapter 6.2.6 Return codes in the Reason element for the RRD area 	string(3) A07	P
text	Text clarifying reason code meaning <ul style="list-style-type: none"> For reason texts see chapter 6.2.6 Return codes in the Reason element for the RRD area 	xs:string(512) Schedule partially accepted.	P
Confirmed_TimeSeries		Structure (frequency: 1..2)	
mRID	Unique time series identifier generated by the source system of the sender.	xs:string(60) 20230311_A01_8591824099902_1	P
version	Version of time series generated by the source system of the sender.<1;999>	xs:string [1-9]([0-9]){0,2} 1	P
businessType	Time series business type: <ul style="list-style-type: none"> A02 - Internal trade (domestic RD entered by participants or PXE) A06 - External trade without explicit capacity (foreign RD entered ČEPS). 	string(3) {A02; A06}	P
product	Product type: <ul style="list-style-type: none"> 8716867000016 - ActivePower 	string(13) 8716867000016	P
objectAggregation	Time series value aggregation level subject: <ul style="list-style-type: none"> A03 - Party 	string(3) A03	P
in_Domain.mRID	Identification of a delivery area into which the product is delivered.	xs:string(18) 10YCZ-CEPS-----N	P
in_Domain.mRID.codingScheme	Coding scheme of the identification of a delivery area into which the product is delivered: <ul style="list-style-type: none"> A01 – EIC code (Energy Identification Coding Scheme) 	string(3) A01	P
out_Domain.mRID	Identification of a delivery area from which the product is taken.	xs:string(18) 10YCZ-CEPS-----N	P
out_Domain.mRID.codingScheme	Coding scheme of the identification of a delivery area from which the product is taken: <ul style="list-style-type: none"> A01 – EIC code (Energy Identification Coding Scheme) 	string(3) A01	P
in_MarketParticipant.mRID	Identification of the buying participant (EAN code).	string(16) 8591824099902	P
in_MarketParticipant.mRID.codingScheme	Coding scheme of the identification of the buying participant: <ul style="list-style-type: none"> A10 – EAN code (European Article Number) 	string(3) A10	P
out_MarketParticipant.mRID	Identification of the selling participant (EAN code).	string(16) 8591824099703	P
out_MarketParticipant.mRID.codingScheme	Coding scheme of the identification of the selling participant:	string(3) A10	P

⁵⁷ The A12 value is supported for querying historical long-term foreign charts

Element/Attribute		Description	Data type and example ⁵⁴	Usage in message ⁵⁵
		<ul style="list-style-type: none"> A10 – EAN code (European Article Number) 		
	measurement_Unit.name	Unit of time series values <ul style="list-style-type: none"> MAW (Mega watt) 	string(3) MAW	P
	<i>Period</i>	<i>Structure</i>		
	<i>timeInterval</i>	<i>Structure</i>		
	start	Beginning of time interval of a given delivery day at ISO 8601, UTC format: YYYY-MM-DDThh:00Z Equals to <i>schedule_Period.timeInterval.start</i>	xs:string(17) 2024-03-10T23:00Z	P
	end	End of time interval of a given delivery day at ISO 8601, UTC format: YYYY-MM-DD+1Thh:00Z Equals to <i>schedule_Period.timeInterval.end</i>	xs:string(17) 2024-03-11T23:00Z	P
	resolution	Delivery period time interval: <ul style="list-style-type: none"> PT15M – 15 minutes delivery period PT60M – 60 minutes delivery period 	xs:duration {PT15M, PT60M}	P
	<i>Point</i>	<i>Structure (1..n)</i>		
	position	Sequence with a starting value of 1. There are as many points as many resolutions fit into the given time series interval (timeInterval). Usually it is: <ul style="list-style-type: none"> 1..96 (92/100 – in case of SCC/LCC days) points for 15min resolution 1..24 (23/25 – in case of SCC/LCC days) points for 60min resolution 	xs:integer; <1;999999> 23	P
	quantity	Amount of energy for each interval with an accuracy of 3 decimal places (positive value, decimal places separator symbol is '.').	xs:decimal 4820	P
	<i>Reason</i>	<i>Structure (1..n)</i>		
	code	Reason code at the level of received document <ul style="list-style-type: none"> List of reason codes – see chapter 6.2.6 Return codes in the Reason element for the RRD area 	string(3) A08	P
	text	Text clarifying reason code meaning <ul style="list-style-type: none"> For reason texts see chapter 6.2.6 Return codes in the Reason element for the RRD area 	xs:string(512) The time series has been successfully matched.	P

6.2.6. Return codes in the Reason element for the RRD area

Return codes and their detailed description for the RRD area in messages:

- Acknowledgement_MarketDocument
- AnomalyReport_MarketDocument
- Confirmation_MarketDocument

Table 37 - The return codes of the Reason.code, Reason.text attributes for the RRD region

code	text
A01	Message was received and successfully validated.
A02	Error when validating XML file. %s

code	text
A02	Error in period %d: volume is required data.
A02	Invalid area code %s.
A02	Invalid delivery date %s.
A02	Message fully rejected.
A02	Missing parameter: volume.
A02	Missing required parameter: delivery date
A02	Not supported/implemented type of document
A04	A period time interval is not the same as schedule interval.
A04	The time interval is to be within one delivery day only.
A06	Schedule accepted.
A07	Schedule partially accepted.
A09	Time series not matching.
A20	Time series fully rejected.
A21	Time series accepted with specific time interval errors.
A22	A counterparty of schedules sent by PXE is to be dedicated PXE's subject of settlement.
A22	In and Out party have to be different in one RD.
A22	In/Out party can't be exchange or TSO in case of internal daily RD not sent by exchange (PXE).
A22	In/Out party Invalid.
A22	The same pair of in/out party is not allowed in more than one time series within one schedule document.
A23	Invalid In Area.
A23	Invalid Out Area.
A23	The In/Out area is unknown or not allowed.
A28	Counterpart time series missing
A29	Counterpart time series quantity differences.
A41	Not supported resolution.
A42	Quantity difference between TSs with the same version number is not allowed.
A42	RD volume is out of specified minimum and maximum value.
A42	Unpermitted number of digits before/after the decimal point.
A46	Signed values are not allowed.
A49	A position is missing or too many.
A49	Non permitted duplicity position in one time series.
A50	At least one time series version is to be equal to document version.
A50	Superior TS version to document version is not allowed.
A51	Document with higher version already exists in the system.
A51	Message identification conflict.
A51	Message identification is already in the system.
A51	The schedule message is already in the system but with different identification.
A51	Within one schedule document only schedules with one counterparty are allowed.
A52	A time series is not contained in a new version of the message. Message rejected.
A53	A schedule receiver is to be Czech imbalance settlement responsible party. (OTE, a.s.)

code	text
A53	Receiving party incorrect.
A55	Same identification of the time series for another In/Out party. Use another one.
A55	The identification of the time series is duplicated or incorrect. Time series will be rejected.
A57	GCT for receiving schedule messages is not open yet or has passed. Message rejected.
A57	Time series of registered document are not in compliance with conditions for RD registration in corrective session.
A62	For this business type is required an item ReqCounterParty.
A62	Invalid business type.
A69	Mandatory attributes missing.
A78	A counterparty of schedules sent by non-exchange participant is not to be dedicated PXE's subject of settlement.
A78	A sender of daily internal schedule is to be equal to subject party.
A78	A sender of schedule doesn't correspond to the participant providing data.
A78	Invalid receiver identification.
A78	Invalid sender coding scheme.
A78	Invalid sender identification.
A78	Item ReqCounterParty invalid.
A78	Item ReqCounterPartyCodingScheme invalid.
A78	Item ReqSenderCodingScheme invalid.
A78	Item ReqSenderIdentification invalid.
A78	Item ReqSenderRole invalid.
A78	Item ReqSubjectParty invalid.
A78	Item ReqSubjectPartyCodingScheme invalid.
A78	Sender identification and/or role invalid.
A78	Only TSO is accepted as a sender of the external schedule.
A78	Sender role invalid.
A79	Process type invalid.
A80	Domain invalid.
A81	Invalid MatchingPeriod.
A81	The end of matching period interval is to be the same as of schedule interval.
A81	The matching period interval is out of the range of the schedule interval.
A81	The matching period interval is to be shorted with each subsequent intraday schedule.
A84	The time series is not part of final position - it has been replaced by valid time series with higher version.
A88	The time series has been successfully matched.
A89	The zeroed time series has been ignored and not matched since it does not figure in a counterparty transmission. All are correctly equal to zero.
A94	For this message type is required an item ReqMatchingPeriod.
A94	Invalid message type.
A94	Invalid receiver coding schema.
A94	Invalid receiver role.
A94	System error: %s
Z01	In or Out party %s1 is not a subject of settlement and there is no relation to any party responsible for its imbalances.

code	text
Z02	RRD not allowed by balance responsible party of In/Out party %s1.
Z03	In or Out party %s1 without valid contract to access RRD (from %s2 to %s3).
Z04	The user does not have the required permission to realize this operation.
Z05	An invalid request (SR) data - duplicity or no document found.
Z06	Final external schedule cannot be replaced by intermediate one
Z07	RD annulled by the system due to finish of participant %s1 registration.
Z08	A subject party is to be either In party or Out party.
Z09	A sender of zeroing schedule is to be the same in the being zeroed schedule.
Z10	There is no schedule to be cancelled. Zeroing schedule has been rejected.
Z11	Subject party of the RD is related to locked SS. Locked participant cannot be a participant of any transaction on energy market.
Z13	Receiver role is invalid.
Z14	Classification type invalid.
Z15	Subject party invalid.
Z15	Subject role invalid.
Z16	Invalid product.
Z17	Invalid object aggregation.
Z18	Unexpected measurement unit.
Z19	Invalid/not supported coding scheme.
Z20	Participant %s1 does not meet the guarantee limit requirements.
Z21	Meets guarantee: Guarantee limits are almost used up.
Z22	Other anomaly.
Z23	Schedule has been accepted and is waiting for FS calculation.
Z23	Waiting for FS

6.2.7. RESPONSE

The RESPONSE message is used for sending mass RRD messages.

Table 38 – RRD RESPONSE

Element/Attribute	Description	Data type and example ⁵⁸	Usage in messages ⁵⁹
RESPONSE			
/Standard Message Header	A description of the standard header can be found in chapter 3.1.1Standard OTE message header format	{/message-code=981; */message-code=992}	P
Reference			

⁵⁸ Example:

A01	<i>Value example</i>
A05	<i>Constant</i>
{A01; A10}	<i>List of possible constants</i>

⁵⁹ Usage in messages: P = Mandatory item; N/A = Item not used

Element/Attribute	Description	Data type and example ⁵⁸	Usage in messages ⁵⁹
*/id	Identification of the previous message. Numeric entry: max. 35 digits.	Xsd:string 76638	N/A
Reason			P
	Text description of messages/warnings/errors, see chapter, see chapter 6.2.7.1 Mass ERD messages	(MSG5505) Query executed. No data found.	P
*/code	Message/warning/error number, see chapter 6.2.7.1 Mass ERD messages Integer value: min. value 1; max. 8 digits.	Xsd:string 5505	P
*/type	Identification of the message type. Alphanumeric entry: fixed length 3 characters.	Xsd:string A03	P
*/result-code	Extended report/warning/error number. It is a 6-digit alphanumeric string in the form M<mxxxx>, where: <ul style="list-style-type: none"> m - module code the result code is originating from: <ul style="list-style-type: none"> 4 – Realization diagrams 0 – Other unclassified and system messages xxxx – numerical identification of reports/warnings/errors, see the "code" attribute, for list of error see chapter 6.2.7.1 Mass ERD messages Alphanumeric entry: fixed length of 6 characters	xsd:string M45505	P

6.2.7.1. Mass ERD messages

The ERD module sends mass messages to the accounting entities. These are the following messages (identified by message-code):

Table 39 - Bulk RRD messages

Message-code	Message type	Code	Message content
981	Postponement ERD deadline	88236	Change was made to ERD closures %session name% (session start: %dd.mm.yyyy hh24:mi:ss%, session closure: %dd.mm.yyyy hh24:mi:ss%, session results: %dd.mm. yyyy hh24:mi:ss%)
992	ERD aggregation	83421	RD aggregation was done for delivery day %dd.mm.yyyy%.

7. Settlement of Markets (SoM) and Imbalances (SoI)

7.1. SoM and SoI Communication Scenarios

The schematic representation of communication scenarios does not specify a specific real-world call to the relevant web service and does not address specific differences in Server-Server and Client-Server communication, for the sake of simplicity it only shows in which message format the MP transmits the given request and which message format is provided as a response.

The methods of communication for individual SoI communication scenarios are summarized in the following table, a detailed description of the mentioned methods of communication and relevant web services is given in [1].

Table 40 – Methods of communication for communication scenarios SoM and SoI

Communication scenario	Method of communication
Data Request - Final Plan (chapter 7.1.1)	Asynchronous communication scenario
Data Request - Breakdown of Settlement Results (chapter 7.1.2)	Asynchronous communication scenario
Data Request - Settlement Results (Electricity) (chapter 7.1.3)	Asynchronous communication scenario
Data Request - Statistical data of imbalance settlement (chapter 7.1.4)	Asynchronous communication scenario
Data Request - Settlement Results (Gas) (chapter 7.1.5)	Asynchronous communication scenario

7.1.1. Data Request - Final Plan

The request will make it possible to find out the total of traded and contracted quantities (energy in MWh) of the market participant, which are then the basis for settlement of markets and imbalances. Data can be obtained by querying:

- **Current traded quantity** – continuously aggregated traded and contracted values for a given delivery day broken down by individual electricity markets/areas:
 - IDA data is available after the publication of the results of the given IDA auction
 - DM data is available after DM results are published
 - IM data is available after the aggregation of the relevant IM contract
 - RRD data is available after performing the aggregation of the relevant RRD session.

Query result is provided

- IDA, DM and IM in the difference of the time period in which the settlement of the given market is carried out for the given delivery day⁶⁰,
- RRD in the resolution of the period corresponding to the resolution of the settlement of imbalances period for the given delivery day.

⁶⁰ If on the given delivery day it is possible to trade on the given market in 15-minute resolution (or with 15-minute contracts), the settlement of the given market will be carried out in 15-minute resolution.

- **Settlement version "Daily settlement of DM"** - aggregate traded quantity on DM, which was the basis for the Daily Settlement of DM. The result of the query is provided in the resolution in which the settlement of the Daily Market is carried out for the given delivery day ⁶¹.
- **Settlement version "Daily settlement of IDA"** - aggregate traded quantity on IDA, which was the basis for the Daily IDA Settlement. The result of the query is provided in the resolution in which the settlement of the IDA market is carried out for the given delivery day.⁶²
- **Settlement version "Daily settlement of IM"** - aggregated traded quantity on IM, which was the basis for the Daily IM settlement. The result of the query is provided in the resolution in which the settlement of the Intraday market is carried out for the given delivery day.⁶³
- **Settlement Version "Daily settlement of imbalances", "Monthly settlement of imbalances", "Final monthly settlement of imbalances"**:
 - Aggregated traded and contracted quantity values in the breakdown of individual markets/areas (IDA, DM, IM, RRD), which were the basis for settlement of imbalances (for daily, monthly or final monthly).
 - The result of the query is provided in the resolution in which the settlement of imbalances is performed for the given delivery day.

One action represents exactly one request to find out the current Final plan for a given delivery day or to find out the Final plan for the selected version of settlement on a given delivery day. Within this communication scenario, OTE data formats are used. The meaning of the individual items of the message formats used is given in the chapter 7.3 Identification of SoM and SoI profiles.

As a result, 1 message pair is provided as part of the response:

- RESPONSE containing the result of processing the Final plan data request
- ISOTEDATA containing Final plan data (the message can contain 1 to n ISOTEDATA elements). This message is not provided if Final plan data is not available for the required request parameters. If there is no value for a delivery period, then this period is not part of the data copy.

If the formal validation of the instruction is not fulfilled, only a negative RESPONSE message is returned.

In the result of the query, both the quantity and the amount are given by "Profile identification". The quantity value is:

- negative if it is a buy (consumption),
- positive if it is a sell (delivery).

⁶¹ If on the delivery day it was possible to trade on DM in 15-minute resolution, DM settlement will be carried out in 15-minute resolution.

⁶² If trading on the IDA market with a 15-minute resolution was enabled on the delivery day, the settlement of the IDA market will be carried out with a 15-minute resolution.

⁶³ If it was possible to trade on IM with 15-minute contracts on the given delivery day, the settlement of IM will be carried out in 15-minute resolution.

The amount (reported only in IM market profiles) then means the total amount in EUR for the indicated quantity:

- positive amount = receivable of SS towards OTE,
- negative amount = payable of SS to OTE.

The list of used profiles is given in the chapter 7.3 Identification of SoM and SoI profiles.

Note 1: If the sender of the request is the **Exchange (PXE)**, the results for the daily market are returned as follows:

- daily market data whose source system was the "PXE" system.
- all daily market data, regardless of the source entry system ("PXE" or "OTE"), of those market participants for whom the Exchange can enter orders on DM and at the same time have the defined activity "Publication of non-exchange data for the Exchange".

Note 2: In the case of **trades of IM block contracts**, the traded quantity of a given trade is spread over the individual periods of the trade's underlying contracts, i.e. for example, in the case of a sell block trade of 10MW of delivered power formed by hourly underlying contracts in periods 8 and 9, the quantity of 10MW is spread over in each 60 min period of the given block contract. The traded quantity of block contract trades is aggregated gradually, i.e. by each aggregation process of every individual underlying contract launched sequentially.

Note 3: If a **state of emergency** is declared in a given period, the Final plan data in this period is provided as follows:

- Aggregated trades on IDA, DM and IM with data in 15-minute resolution periods
 - for regular participant – during periods of emergency, trades with zero quantity in MWh are provided.
 - for participant with Shipping Agent DM, Shipping Agent IDA, and Shipping Agent IM activities – during periods of emergency, trades are provided without changes in quantity in MWh.
- Aggregated trades on DM with data in 60-minute resolution periods
 - for regular participant – transactions are adequately reduced by the agreed amount in MWh in quarter-hourly emergency status periods of 60 minutes.
 - for participant with Shipping Agent DM – are transactions during periods of emergency provided without change in quantity in MWh.
- Domestic diagrams are provided with zero quantity during emergency periods
- Foreign diagrams are provided with the quantity without change

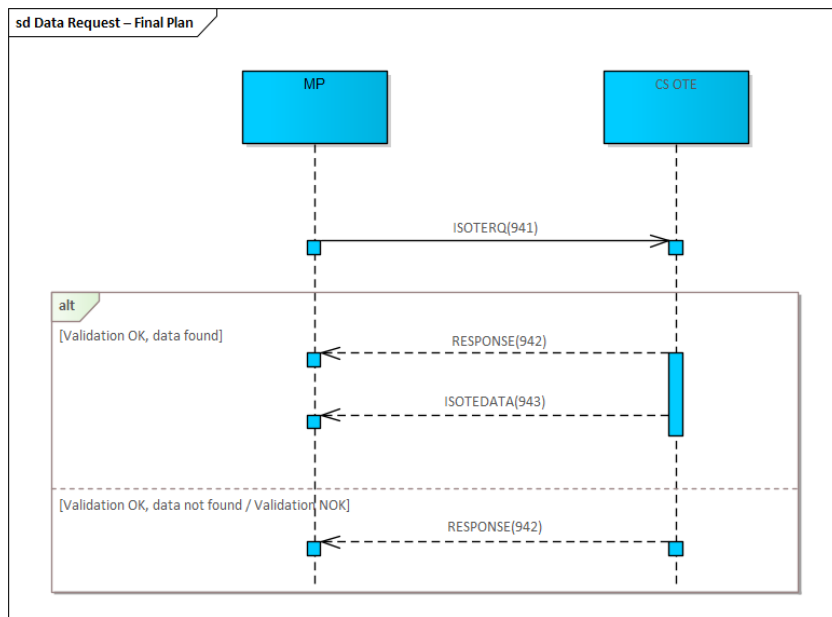

Figure 15 - Communication Scenario - Data Request - Final plan

7.1.2. Data Request - Breakdown of Settlement Results

The request will make it possible to find out the breakdown of the results of the market settlement and the settlement of imbalances by periods of the given delivery day and the version of the settlement. One action represents exactly one request to find out settlement data. Within this communication scenario, OTE data formats are used. The meaning of the individual items of the message formats used is given in the chapter 7.3 Identification of SoM and SoI profiles.

As a result, 1 message pair is provided as part of the response:

- RESPONSE containing the result of processing the request
- ISOTEDATA containing a breakdown of accounting results by period (the message can contain 1 to n ISOTEDATA elements). This data description message is not provided if data is not available for the requested delivery day and the requested settlement version. If there is no value for a settlement period, then this period is not part of the data copy.

If the formal validation of the instruction is not fulfilled, only a negative RESPONSE message is returned.

In the result of the query, the profiles show sums and quantities, which can take on positive and negative values. The amount then means the total amount for the specified quantity in the specified currency:

- positive amount = receivable of SS towards OTE,
- negative amount = payable of SS to OTE.

The list of used profiles is given in the chapter 7.3 Identification of SoM and SoI profiles

The query result can be provided in multiple time period resolutions. Most profiles are listed in the resolution at which the required settlement version (PT15M or PT60M) is settled for the delivery day. Some of the profiles (such as fees) will be presented in daily resolution "PID" or in monthly resolution "PIM", in that case this information is provided for the described profile in the chapter 7.3 Identification

of SoM and SoI profiles. Data in a monthly resolution is returned as a result in the case when the request refers to the delivery day, which is the last calendar day in the given month.

Note 1: If the sender of the request is the **Exchange (PXE)**, the results for the daily market are returned as follows:

- daily market data whose source system was the "PXE" system.
- all daily market data, regardless of the source entry system ("PXE" or "OTE"), of those market participants for whom the Exchange can enter orders on DM and at the same time have the defined activity "Publication of non-exchange data for the Exchange".

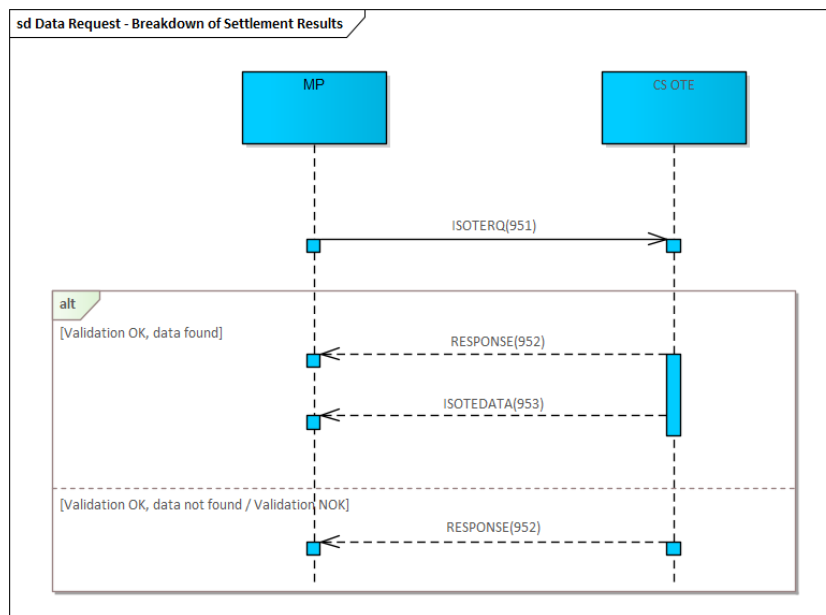

Figure 16 - Communication scenario - Data Request - Breakdown of Settlement Results

7.1.3. Data Request - Settlement Results (Electricity)

The request will make it possible to find out the results of the market settlement and the settlement of imbalances for the given day of delivery and settlement version. One action represents exactly one request to find out settlement data. Within this communication scenario, OTE data formats are used. The meaning of the individual items of the message formats used is given in the chapter 7.3 Identification of SoM and SoI profiles.

As a result, 1 message pair is provided as part of the response:

- RESPONSE containing the result of processing the request
- ISOTEDATA containing settlement results aggregated at the delivery day level. This data description message is not provided if data is not available for the requested delivery day and the requested settlement version.

If the formal validation of the instruction is not fulfilled, only a negative RESPONSE message is returned.

In the result of the query, the profiles show sums and quantities, which can take on positive and negative values. The amount then means the total amount for the specified quantity in the specified currency:

- positive amount = receivable of SS towards OTE,
- negative amount = payable of SS to OTE.

List of used profiles is given in the chapter 7.3.4 Settlement results (gas)

The query result can be provided in multiple time period resolutions. As these are results per day, most profiles are given at the resolution of one delivery day "P1D". Some of the profiles (such as monthly fees) will be listed in the monthly resolution "P1M", in which case this information is given for the described profile in the chapter 7.3 Identification of SoM and SoI profiles. As a result, data in a monthly resolution is returned in the event that the request concerns the day of delivery, which is the last calendar day of the given month.

Note 1: If the sender of the request is the **Exchange (PXE)**, the results for the daily market are returned as follows:

- daily market data whose source system was the "PXE" system.
- all daily market data, regardless of the source entry system ("PXE" or "OTE"), of those market participants for whom the Exchange can enter orders on DM and at the same time have the defined activity "Publication of non-exchange data for the Exchange".

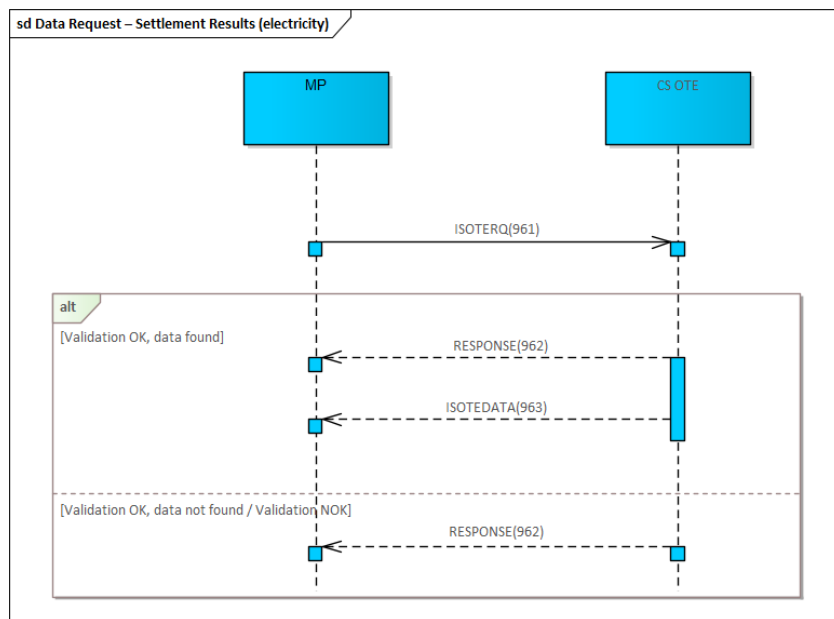

Figure 17 - Communication scenario - Data Request - Settlement Results (electricity)

7.1.4. Data Request - Statistical data of imbalance settlement

The request will make it possible to find out the statistical data of the settlement of imbalances for the given delivery day and the given version of the settlement. One action represents exactly one request to find out settlement data. Within this communication scenario, OTE data formats are used. The meaning

of the individual items of the message formats used is given in the chapter 7.3 Identification of SoM and SoI profiles.

As a result, 1 message pair is provided as part of the response:

- RESPONSE containing the result of processing the request
- ISOTEDATA containing statistical data of settlement of imbalances. This data description message is not provided if data is not available for the requested delivery day and the requested settlement version. If there is no value for a settlement period, then this period is not part of the data copy.

If the formal validation of the instruction is not fulfilled, only a negative RESPONSE message is returned.

In the result of the query, the profiles show prices, amounts and quantities, which can take on positive and negative values. The list of used profiles is given in the chapter 7.3 Identification of SoM and SoI profiles.

The result of the query is provided in the resolution of the time period in which the settlement of the required settlement version (PT15M or PT60M) is performed for the given delivery day.

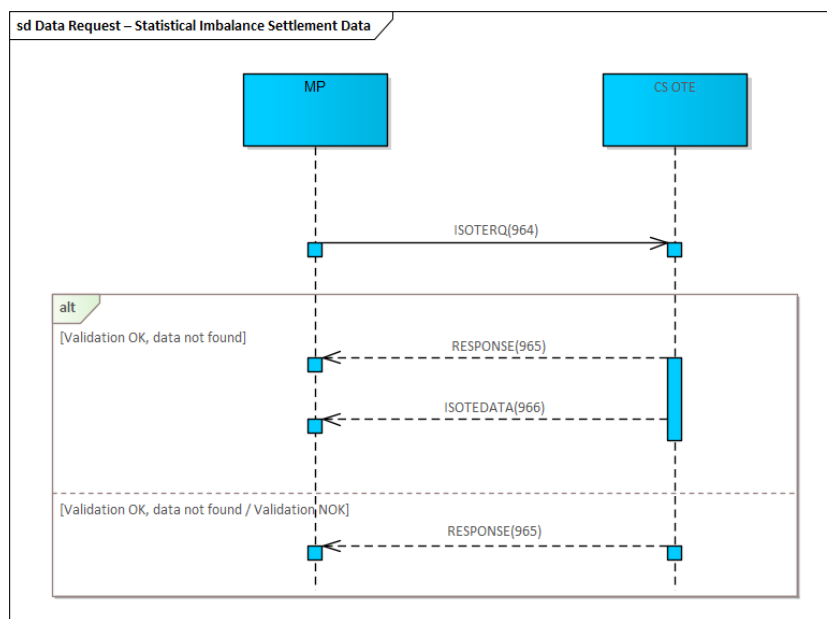

Figure 18 - Communication scenario - Data Request - Statistical Data of imbalance settlement

7.1.5. Data Request - Settlement Results (Gas)

The request will make it possible to find out the settlement results for the given delivery day and the given settlement version. One action represents exactly one request to find out settlement data. Within this communication scenario, OTE data formats are used. The meaning of the individual items of the message formats used is given in the chapter 7.3 Identification of SoM and SoI profiles.

As a result, 1 message pair is provided as part of the response:

- RESPONSE containing the result of processing the request

- ISOTEDATA containing settlement results for the entire gas day. This data description message is not provided if data is not available for the requested gas day and settlement version.

If the formal validation of the instruction is not fulfilled, only a negative RESPONSE message is returned.

In the result of the query, the profiles show sums and quantities, which can take on positive and negative values. The list of used profiles is given in the chapter 7.3 Identification of SoM and SoI profiles.

The amount then means the total amount for the specified quantity in the specified currency:

- positive amount = receivable of SS towards OTE,
- negative amount = payable of SS to OTE.

The list of used profiles is given in the chapter 7.3.4 Settlement results (gas).

The query result can be provided in multiple time period resolutions. As these are gas results, most profiles are given in “P1D” day resolution. Some of the profiles (such as monthly fees) are listed in the monthly resolution “P1M”, in which case this information is given for the described profile in the chapter 7.3 Identification of SoM and SoI profiles. Data in a monthly resolution is returned as a result in the case when the request refers to the delivery day, which is the last calendar day in the given month.

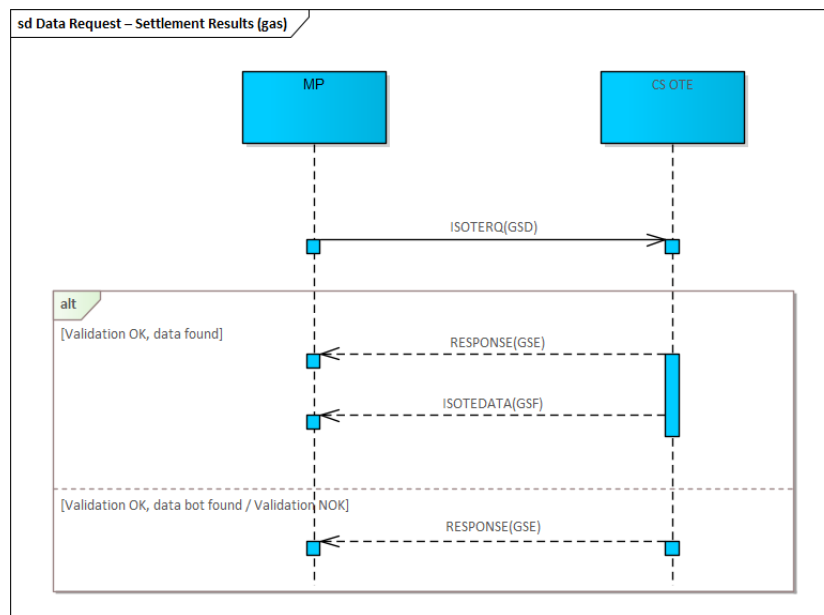

Figure 19 - Communication scenario - Data Request - Settlement Results (Gas)

7.2. Content of SoM and SoI data messages

The chapter describes the content of data messages used within communication scenarios for SoM and SoI to MP. See also [2], where custom template files of individual data messages and their complete definitions are available.

7.2.1. ISOTEREQ

Table 41 - Content of SoM and Sol data messages (electricity) – ISOTEREQ

Element/Attribute	Description	Data type or Example ⁶⁴	Usage in messages ⁶⁵				
			941	951	961	964	GSD
ISOTEREQ							
/Standard Message Header	A description of the standard header can be found in chapter 3.1.1 Standard OTE message header format	{/message-code=941 request: Final plan; */message-code=951 request: Breakdown of settlement results; */message-code=961 request: Settlement Results (Electricity); */message-code=964 request: Statistical data of imbalance settlement; */message-code=GSD request: Settlement Results (Gas)}	P	P	P	P	P
Document							
*/market	Market type: <ul style="list-style-type: none"> IDA – Intraday auction DM – Day ahead market IM – Intraday market RRD – Realization diagrams 	xsd:string {IDA; DM; IM; RRD}	V	N/A	N/A	N/A	N/A
Trade							
*/trade-day	Delivery day in yyyy-mm-dd format	xsd:date 2024-06-18	P	P	P	P	P
*/version	Settlement version: <ul style="list-style-type: none"> 1 – Daily settlement of DM, 2 – Daily settlement of imbalances, 3 – Monthly settlement of imbalances, 4 – Final monthly settlement of imbalances, 5 – Settlement of emergency state, 6 – Final monthly LP evaluation, 11 - Monthly settlement with gas, 12 - Final monthly settlement with gas, 13 - Daily settlement of IM with gas 15 – Monthly LP evaluation, 16 – Daily settlement of IM, 17 – Daily settlement of IDA 	xsd:string <ul style="list-style-type: none"> pro message-code= 941: {1; 2; 3; 4; 16; 17} pro message-code=951: {1; 2; 3; 4; 5; 16; 17} pro message-code=961: {1; 2; 3; 4; 5; 6; 15; 16; 17} pro message-code=964: {2; 3; 4} pro message-code=GSD {11; 12; 13} 	PP	P	P	P	P

The question on the Final plan (941) can be asked in two variants:

⁶⁴ Example:

A01	Value example
A05	Constant
{A01; A10}	List of possible constants

⁶⁵ Usage in messages: P = Mandatory item; V = Optional item; PP = Conditional Item; N/A = Unused item

Table 42 - Query the current final plan

Element/Attribute	Usage in messages
*/market	Optional item
*/trade-day	Mandatory item

Table 43 - Query for a time snapshot of the final plan according to a specific settlement version

Element/Attribute	Usage in messages
*/trade-day	Mandatory item
*/version	Mandatory item

If the items of both variants are filled in the request, variant No. 2 always takes precedence (the market attribute will be ignored).

7.2.2. RESPONSE

Table 44 - Content of SoM and Sol - RESPONSE data messages

Element/Attribute	Description	Data type or Example ⁶⁶	Usage in messages ⁶⁷
RESPONSE			
/Standard Message Header	A description of the standard header can be found in chapter 3.1.1 Standard OTE message header format	{/message-code=942 response: Final plan; */message-code=952 response: Breakdown of settlement results (Electricity); */message-code=962 response: Settlement results (Electricity); */message-code=965 response: Statistical data of imbalance settlement */message-code=GSE response: Settlement results (gas)}	P
Reference			
*/id	Previous message identification in meaning of ISOTEDATA/ISOTEREQ request, for which the answer is being provided. Numeric entry: max. 35 digits.	Xsd:string 76638	P
Reason			P
	Text description of the message/ warnings/errors, see chapter 7.2.2.1 Errors/reports for SoM and Sol area - filling in the attribute code, result-code and error-code	(MSG5505) Query executed. No data found.	V
*/code	Message/warning/error number, see chapter 7.2.2.1 Errors/reports for SoM and Sol area - filling in the attribute code, result-code and error-code Numerical item: min. value 1; max. 8 digits.	Xsd:string 5505	P

⁶⁶ Example:

A01	Value example
A05	Constant
{A01; A10}	List of possible constants

⁶⁷ Usage in messages: P = Mandatory item; V = Optional item

Element/Attribute	Description	Data type or Example ⁶⁶	Usage in messages ⁶⁷
*/type	Identification of the message type. Alphanumeric entry: fixed length 3 characters.	Xsd:string A02	P
*/trade-id	Order identification. Numerical item: min. value 1; 18 digits max.	Xsd:string 317871	V
*/version	<ul style="list-style-type: none"> Order version for DM and IDA area Settlement version for message-code= 982 only Numerical item: min. value 1; 3 digits max.	Xsd:string 1	V
*/date-from	Start delivery day of settlement period (for message-code= 982 only) Delivery day in format yyyy-mm-dd	xsd:date 2024-01-30	V
*/date-to	End delivery day of settlement period (for message-code= 982 only) Delivery day in format yyyy-mm-dd	xsd:date 2024-01-30	V
*/date-timestamp	Timestamp of the start of the metering data aggregation process (for message-code= 982 and version=2,3,4,5,6,15 ⁶⁸ only) ISO 8601, in local time	xsd:dateTime 2024-01-30T11:01.17	V
*/external-id	Order Id in the market participant's system. Numerical item: min. value 1; 18 digits max.	Xsd:string 325489	V
*/result-code	Extended report/warning/error number. It is a 6-digit alphanumeric string in the form M<mxxxx>, where: <ul style="list-style-type: none"> m - module code the result code is originating from: <ul style="list-style-type: none"> 8 – Imbalances settlement 0 – Other unclassified and system messages xxxx – numerical identification of messages/warnings/errors, see attribute "code", list of error messages in Sol, see chapter 7.2.2.1 Errors/reports for SoM and Sol area - filling in the attribute code, result-code and error-code Alphanumeric entry: fixed length of 6 characters,	xsd:string M85505	V

7.2.2.1. Errors/reports for SoM and SoI area - filling in the attribute code, result-code and error-code

The chapter defines a list of warnings and error messages that can be expected in a message within the communication scenarios SoM and SoI, with a distinction of the communication scenario in which it can occur. The first table entry is the value that can be found in the code attribute of the Reason XML element in the RESPONSE message, the second table entry defines the text message pattern describing the given warning/error that can be found in the Reason XML element of the RESPONSE message.

Table 45 - Errors/reports for the area of SoM and Sol (electricity) - filling in the attribute code, result-code and error-code

Code	Description	Type ⁶⁹
3119	Error when validating XML file. %s	E
4043	Data not found in processing table.	E

⁶⁸ 2 - Daily settlement of imbalances, 3 – Monthly settlement of imbalances, 4 – Final monthly settlement of imbalances, 5 – Settlement of emergency state, 15 – Monthly LP evaluation, 6 – Final monthly PL evaluation

⁶⁹ Type: E = Error message; I = Informative message; W = Warning

Code	Description	Type ⁶⁹
4051	Invalid type of operation.	E
5011	An error occurred while calling API functions. Error code = %s.	E
5504	Query executed. Data found.	I
5505	Query executed. No data found.	I
5529	Header error: invalid Market type.	E

7.2.2.2. Mass messages for SoM and IS

Settlement entities sent mass messages about settlement execution and data availability by the Settlement module. These are the following messages (identified by message-code):

Table 46 - Mass messages SoM and IS

Message-code	Message
982	Settlement accomplishment notification

7.2.3. ISOTEDATA

Table 47 - Content of SoM and Sol data reports - ISOTEDATA

Element/Attribute	Description	Data type or Example ⁷⁰	Usage in messages ⁷¹				
			943	953	963	966	GSF
ISOTEDATA							
/Standard Message Header	A description of the standard header can be found in chapter 3.1.1Standard OTE message header format	{/message-code=943 copy: Final plan; */message-code=953 copy: Breakdown of settlement results (Electricity); */message-code=963 copy: Settlement results (Electricity); */message-code=966 copy: Statistical data of imbalance settlement; */message-code=GSF copy: Settlement results (Gas)}	P	P	P	P	P
Reference							
*/id	Identification of the previous message in meaning of ISOTEREQ request, for which the answer is being provided. Numeric entry: max. 35 digits.	xsd:string 76638	P	P	P	P	P
Trade	1..n						
*/trade-day	Delivery day in yyyy-mm-dd format	xsd:date 2020-06-18	P	P	P	P	P

⁷⁰ Example:

A01	Value example
A05	Constant
{A01; A10}	List of possible constants

⁷¹ Usage in messages: P = Mandatory item; V = Optional Item; N/A = Unused item

Element/Attribute	Description	Data type or Example ⁷⁰	Usage in messages ⁷¹						
			943	953	963	966	GSF		
*/version	Settlement version: <ul style="list-style-type: none"> 1 – Daily settlement of DM, 2 – Daily settlement of imbalances, 3 – Monthly settlement of imbalances, 4 – Final monthly settlement of imbalances, 5 – Settlement of emergency state, 6 – Final monthly LP evaluation, 11 - Monthly settlement with gas, 12 - Final monthly settlement with gas, 13 - Daily settlement of IM with gas 15 – Monthly LP evaluation, 16 – Daily settlement of IM, 17 – Daily settlement of IDA 	<ul style="list-style-type: none"> pro message-code= 943: {1; 2; 3; 4; 16; 17} pro message-code=953: {1; 2; 3; 4; 5; 16; 17} pro message-code=963: {1; 2; 3; 4; 5; 6; 15; 16; 17} pro message-code=966: {2; 3; 4} pro message-code=GSF {11; 12; 13} 	PP	P	P	P	P		
*/resolution	Time resolution of the periods of the settlement data: <ul style="list-style-type: none"> PT15M – period in 15 minutes resolution PT60M – period in 60 minutes resolution P1D – period in day resolution P1M – period in month resolution 	xsd:string {PT15M; PT60M; P1D, P1M}	P	P	P	P	P		
TimeData	0..1								
*/datetime	LP change date According to ISO 8601, in UTC format, see chapter 3.1.2 Date and time values in messages.	xsd:dateTime 2020-06-18T16:32:03Z	N/A	N/A	V	N/A	N/A		
ProfileData	1..n								
*/profile-role	Profile identification <ul style="list-style-type: none"> List and description of the used profiles is given in the chapter 7.3 Identification of SoM and Sol profiles. 	xsd:string XC55	P	P	P	P	P		
/unit	Unit related to the value (/value) specified within provide profile data	xsd:string {MWH; -; CZK/MWH, CZK; EUR}	P	P	P	P	P		
Data	1..n								
/period	Identification of the delivery period / settlement period for which the values (/value) are returned. The defined interval depends on the value of the resolution attribute: <ul style="list-style-type: none"> if resolution = PT15M, then the interval is 1 to 100 depending on the number of hours of the business day (winter/summer transition – 92; summer/winter transition – 100), 	xsd:string 15	P	P	P	P	P		

Element/Attribute	Description	Data type or Example ⁷⁰	Usage in messages ⁷¹					
			943	953	963	966	GSF	
	<ul style="list-style-type: none"> if resolution = PT60M, then the interval is 1 to 25 depending on the number of hours of the business day (winter/summer transition – 23; summer/winter transition – 25). if resolution = P1D, then the interval is 1 if resolution = P1M then interval is 1 For individual detail records, the item is unique and is sorted in ascending order. Numerical item: min. value 1, max. 3 digits).							
	/value	Value whose meaning defines a profile (/profile-role): <ul style="list-style-type: none"> For quantity, a value with up to 5 decimal places is expected. For price/amount, a value with 2 decimal places is expected. Numeric item with a precision of max. 5 decimal places (decimal separator: ".").	xsd:string	P	P	P	P	P
	Party	0..1						
	id	Participant identification (EAN code). Numeric entry: fixed length of 13 digits.	xsd:string 8591824000007	P	P	P	N/A	N/A
	role	Role of the market participant: <ul style="list-style-type: none"> TO – owner of resulting data 	xsd:string TO	P	P	P	N/A	N/A

7.3. Identification of SoM and SoI profiles

7.3.1. Final plan

List of used profiles in the message Final plan (message-code = 943):

Table 48 - Profile List - Final plan

Usage in message	Assignment profile to settlement version	Quantity			Amount ⁷²		
		Profile	Unit	Profile description	Profile	Unit	Profile description
*/message-code	*/version	*/profile-role	*/unit		*/profile-role	*/unit	
943	Version not specified or {1, 2, 3, 4}	SC19	MWH	DM - negative energy - consumption (spot order)	n/a	n/a	
943	Version not specified or {1, 2, 3, 4}	SC20	MWH	DM - positive energy - supply (spot order)	n/a	n/a	
943	Version not specified or {2, 3, 4, 16}	SC21	MWH	IM - negative energy (consumption) for negative prices	SP21	EUR	IDM – amount for negative energy (consumption) at negative prices(delivery) (receivable)
943	Version not specified or {2, 3, 4, 16}	SC22	MWH	IM - positive energy (supply) for positive prices	SP22	EUR	IDM – amount for positive energy(delivery) for positive prices (receivable)
943	Version not specified or {2, 3, 4}	SC23	MWH	Domestic RD - negative energy (consumption)	n/a	n/a	
943	Version not specified or {2, 3, 4}	SC24	MWH	Domestic RD - positive energy (supply)	n/a	n/a	
943	Version not specified or {2, 3, 4}	SC25	MWH	Foreign RD - negative energy (consumption)	n/a	n/a	

⁷² n/a = Corresponding amount profile to the quantity profile is not defined



Usage in message	Assignment profile to settlement version	Quantity			Amount ⁷²		
		Profile	Unit	Profile description	Profile	Unit	Profile description
*/message-code	*/version	*/profile-role	*/unit		*/profile-role	*/unit	
943	Version not specified or {2, 3, 4}	SC26	MWH	Foreign RD - positive energy (supply)	n/a	n/a	
943	Version not specified or {2, 3, 4, 17}	SC31	MWH	IDA - negative energy - consumption (spot order)	n/a	n/a	
943	Version not specified or {2, 3, 4, 17}	SC32	MWH	IDA - positive energy – supply (spot order)	n/a	n/a	
943	Version not specified or {1, 2, 3, 4}	SC50	MWH	DM- negative energy - consumption (FS order)	n/a	n/a	
943	Version not specified or {1, 2, 3, 4}	SC51	MWH	DM - positive energy - supply (FS order)	n/a	n/a	
943	Version not specified or {2, 3, 4, 16}	SC71	MWH	IM - negative energy (consumption) for positive prices ⁷³	SP71	EUR	IM - amount for negative energy (consumption) for positive prices (payable)
943	Version not specified or {2, 3, 4, 16}	SC72	MWH	IM - positive energy (supply) for negative prices ⁷⁴	SP72	EUR	IM – amount for positive energy (supply) for negative prices (payable)

7.3.2. Breakdown of Settlement results and Settlement results (electricity)

The chapter specifies the list of profiles used in the reports Breakdown of Settlement results (message-code = 953) and Settlement results - electricity (message-code = 963):

⁷³ Note: also includes negative energy at zero cost

⁷⁴ Note: also includes positive energy at zero cost



- Amounts and quantities indicated in individual profiles can take on positive or negative values depending on the type of profile. The information about what value is returned in the profile is defined either by the Profile Description itself or this information is specified in more detail in the Note column.

Table 49 - Profile list – Breakdown of Settlement results and Settlement results (electricity)

Usage in message	Assignment profile to settlement version	Quantity ⁷⁵			Amount			Note
		Profile	Unit	Profile description	Profile	Unit	Profile description	
		*/message-code	*/version		*/profile-role	*/unit		
953, 963	{3, 4}	n/a	n/a		ST15	CZK	Monthly CDS Access Fee - Negative Amount (payable)	Period resolution: */resolution="P1M"
953, 963	{3, 4}	n/a	n/a		ST16	CZK	Monthly fee for settlement of imbalances with electricity - negative amount (payable)	Period resolution: */resolution="P1M"
953, 963	{2, 3, 4}	n/a	n/a		ST17	CZK	Surplus of settlement of imbalances and BE	+/- (amount)
953, 963	{3, 4}	n/a	n/a		ST18	CZK	REMIT monthly fee - fixed electricity fee - negative amount (payable)	Period resolution: */resolution="P1M"
953, 963	{17}	SC01	MWH	IDA fee – total traded energy	SP01	CZK	IDA fee - negative amount for total traded energy (payable)	Profiles SC01,SP01 will be provided in the 953 report only in historical data for delivery days up to and including 12/31/2024, when the charge was determined by delivery day periods.
953, 963	{1}	SC05	MWH	DM fee – total traded energy	SP05	CZK	DM fee - negative amount for the total traded energy (payable)	Profiles SC05,SP05 will be provided in the 953 report only in historical data for delivery days up to and including 12/31/2024, when the charge was

⁷⁵ n/a = Corresponding quantity profile to the amount profile is not defined



Usage in message	Assignment profile to settlement version	Quantity ⁷⁵			Amount			Note
		Profile	Unit	Profile description	Profile	Unit	Profile description	
		*/profile-role	*/unit		*/profile-role	*/unit		
								determined by delivery day periods.
953, 963	{2, 3, 4}	SC06	MWH	Quantity of negative SS imbalance at negative settlement price	SP06	CZK	Price for the negative imbalance of the SS at a negative settlement price (receivable)	imbalances profiles (SC06 and SC07) are also provided for participants who are Super SSs, for each of their Subordinate SSs (without financial data). For participants, who delegating responsibility for imbalance (Subordinate SSs), no financial data is provided in imbalances profiles as well.
953, 963	{2, 3, 4}	SC07	MWH	Quantity of positive SS imbalance at positive/nonzero settlement price	SP07	CZK	Price of positive SS imbalance at positive/nonzero settlement price (receivable)	
953, 963	{16}	SC08	MWH	Settlement of IM – negative energy (consumption) for negative prices	SP08	EUR	Settlement of IM – amount for negative energy (consumption) for negative prices (receivable)	
953, 963	{16}	SC09	MWH	Settlement of IM - positive energy (supply) at positive/zero prices	SP09	EUR	Settlement of IM - amount for positive energy(supply) at positive/zero prices (receivable)	
953, 963	{16}	SC10	MWH	IM fee - total energy traded	SP10	CZK	IM fee - negative amount for the total energy traded (payable)	The SC10,SP10 profiles will be provided in the 953 report only in historical data for days of delivery up to and including 12/31/2024, when the charge was determined by day-of-delivery periods.
963	{6, 15}	SC27	MWH	LP evaluation - negative energy	SP27	CZK	LP evaluation - negative amount for negative energy (payable)	
963	{6, 15}	SC28	MWH	LP evaluation - positive energy	SP28	CZK	LP evaluation - positive amount for positive energy (receivable)	
953, 963	{2, 4, 5}	SC29	MWH	Emergency state – positive energy (supply)	SP29	CZK	Emergency state – amount for positive energy (supply)	+/- (amount)
953, 963	{2, 4, 5}	SC30	MWH	Emergency state – negative energy (consumption)	SP30	CZK	Emergency state – amount for negative energy (consumption)	+/- (amount)

2026 OTE, a.s.

Date of revision:
25.05.2026Document name:
D1.4.4_EN_Format_messages_XML_DM-IDA-Sol-RRD-FS-CDS.docx



Usage in message	Assignment profile to settlement version	Quantity ⁷⁵			Amount			Note
		Profile	Unit	Profile description	Profile	Unit	Profile description	
*/message-code	*/version	*/profile-role	*/unit		*/profile-role	*/unit		
953, 963	{2, 3, 4}	SC56	MWH	Quantity of negative SS imbalance at a positive/zero settlement price	SP56	CZK	Price for negative imbalance of SS at positive/zero settlement price (payable)	imbalances profiles (SC56 and SC57) are also provided for participants who are Super SSs, for each of their Subordinate SSs (without financial data). For participants, who delegating responsibility for imbalance (Subordinate SSs), no financial data is provided in imbalances profiles as well.
953, 963	{2, 3, 4}	SC57	MWH	Quantity of positive SS imbalance at negative settlement price	SP57	CZK	Price for a positive SS imbalance at a negative settlement price (payable)	
953, 963	{16}	SC58	MWH	Settlement of IM - negative energy (consumption) at positive/zero prices	SP58	EUR	Settlement of IM – amount for negative energy (consumption) at positive/zero prices (payable)	
953, 963	{16}	SC59	MWH	Settlement of IM - positive energy (supply) for negative prices	SP59	EUR	Settlement of IM - amount for positive energy (supply) for negative prices (payable)	
953, 963	{17}	SC66	MWH	Settlement of IDA – negative energy (consumption) at a negative price (spot orders)	SP66	EUR	Settlement of IDA – amount for negative energy (consumption) at a negative price (spot orders)	
953, 963	{17}	SC67	MWH	Settlement of IDA – negative energy (consumption) at a positive/zero price (spot orders)	SP67	EUR	Settlement of IDA – amount for negative energy (consumption) at a positive/zero price (spot orders)	
953, 963	{17}	SC68	MWH	Settlement of IDA - positive energy (supply) at positive/zero price (spot orders)	SP68	EUR	Settlement of IDA – amount for positive energy (supply) at positive/zero price (spot orders)	
953, 963	{17}	SC69	MWH	Settlement of IDA - positive energy (supply) at a negative price (spot orders)	SP69	EUR	Settlement of IDA – amount for positive energy (supply) at a negative price (spot orders)	
953, 963	{2, 4, 5}	SC79	MWH	Emergency state IDA - export	SP79	CZK	Emergency state IDA – amount for export	+/- (amount)
953, 963	{2, 4, 5}	SC80	MWH	Emergency state IDA - import	SP80	CZK	Emergency state IDA – amount for import	+/- (amount)

2026 OTE, a.s.

Date of revision:
25.05.2026Document name:
D1.4.4_EN_Format_messages_XML_DM-IDA-Sol-RRD-FS-CDS.docx



Usage in message	Assignment profile to settlement version	Quantity ⁷⁵			Amount			Note
		Profile	Unit	Profile description	Profile	Unit	Profile description	
*/message-code	*/version	*/profile-role	*/unit		*/profile-role	*/unit		
953, 963	{2, 3, 4}	SF11	MWH	Quantity of BE+ from AnS activation at positive/zero BE+ price	SG11	CZK	Price for the amount for BE+ from AnS activation at positive/zero BE+ price (receivable)	
953, 963	{2, 3, 4}	SF12	MWH	Quantity of BE- from AnS activation at a negative BE- price	SG12	CZK	Price for the amount for BE- from AnS activation at a negative BE- price (receivable)	
953, 963	{2, 3, 4}	SF61	MWH	Quantity of BE+ from AnS activation at a negative BE+ price	SG61	CZK	Price for the amount for BE+ from AnS activation at a negative BE+ price (payable)	
953, 963	{2, 3, 4}	SF62	MWH	Quantity of BE- from AnS activation at positive/zero BE- price	SG62	CZK	Price for the amount for BE- from activation of AnS at positive/zero price of BE - (payable)	
953, 963	{2, 3, 4}	XC01	MWH	Quantity of positive aggregate SSS imbalance at positive/zero settlement price	XP01	CZK	Price for the amount of positive aggregate SSS imbalance at positive/zero settlement price (receivable)	
953, 963	{2, 3, 4}	XC02	MWH	Quantity of negative aggregate SSS imbalance at negative settlement price	XP02	CZK	Price for the amount of negative aggregate SSS imbalance at negative settlement price (receivable)	
953, 963	{1}	XC03	MWH	Settlement of DM - negative energy - consumption at a positive price (spot orders, OTE portal)	XP03	EUR	Settlement of DM – amount for negative energy - consumption at a positive price (spot orders, OTE portal)	
953, 963	{1}	XC04	MWH	Settlement of DM - positive energy - supply at a positive price (spot orders, OTE portal)	XP04	EUR	Settlement of DM – amount for positive energy - supply at a positive price (spot orders, OTE portal)	
953, 963	{1}	XC05	MWH	Settlement of DM - negative energy - supply at a positive price (FS order)	XP05	EUR	Settlement of DM - amount for negative energy - supply at a positive price (FS order)	
953, 963	{1}	XC06	MWH	Settlement of DM - positive energy - supply at a positive price (FS order)	XP06	EUR	Settlement of DM - amount for positive energy- supply at a positive price (FS order)	

2026 OTE, a.s.

Date of revision:
25.05.2026Document name:
D1.4.4_EN_Format_messages_XML_DM-IDA-Sol-RRD-FS-CDS.docx



Usage in message	Assignment profile to settlement version	Quantity ⁷⁵			Amount			Note
		Profile	Unit	Profile description	Profile	Unit	Profile description	
*/message-code	*/version	*/profile-role	*/unit		*/profile-role	*/unit		
953,963	{1}	XC07	MWH	Settlement of DM (cumulative PXE trades) - negative energy - consumption at a positive price (FS order)	XP07	EUR	Settlement of DM (cumulative PXE trades) - amount for negative energy - consumption at a positive price (FS order)	
953,963	{1}	XC08	MWH	Settlement of DM (cumulative PXE trades) - positive energy - supply at a positive price (FS order)	XP08	EUR	Settlement of DM (cumulative PXE trades) - amount for positive energy - supply at a positive price (FS order)	
953,963	{1}	XC09	MWH	Settlement of DM (cumulative PXE trades) - negative energy - consumption at a positive price (spot orders)	XP09	EUR	Settlement of DM (cumulative PXE trades) - amount for negative energy - consumption at a positive price (spot orders)	
953,963	{1}	XC10	MWH	Settlement of DM (cumulative PXE trades) - positive energy - supply at a positive price (spot orders)	XP10	EUR	Settlement of DM (cumulative PXE trades) - amount for positive energy - supply at a positive price (spot orders)	
953,963	{1}	XC11	MWH	Settlement of DM - negative energy - consumption at a positive price (spot orders, portal PXE)	XP11	EUR	Settlement of DM - amount for negative energy - consumption at a positive price (spot orders, portal PXE)	
953,963	{1}	XC12	MWH	Settlement of DM - positive energy - supply at a positive price (spot orders, portal PXE)	XP12	EUR	Settlement of DM - amount for positive energy - supply at a positive price (spot orders, portal PXE)	
953,963	{2, 3, 4}	XC51	MWH	Quantity of positive aggregated SSS imbalance at a negative settlement price	XP51	CZK	Price for the amount of positive aggregated SSS imbalance at a negative settlement price (payable)	
953,963	{2, 3, 4}	XC52	MWH	Quantity of negative aggregate SSS imbalance at positive/zero settlement price	XP52	CZK	Price for the amount of negative aggregate SSS imbalance at positive/zero settlement price (payable)	
953,963	{1}	XC53	MWH	Settlement of DM - negative energy - consumption at a	XP53	EUR	Settlement of DM - amount for negative energy - consumption at a	

2026 OTE, a.s.

Date of revision:
25.05.2026Document name:
D1.4.4_EN_Format_messages_XML_DM-IDA-Sol-RRD-FS-CDS.docx



Usage in message	Assignment profile to settlement version	Quantity ⁷⁵			Amount			Note
		Profile	Unit	Profile description	Profile	Unit	Profile description	
*/message-code	*/version	*/profile-role	*/unit		*/profile-role	*/unit		
				negative price (spot orders, OTE portal)			negative price (spot orders, OTE portal)	
953, 963	{1}	XC54	MWH	Settlement of DM - positive energy - supply at a negative price (spot orders, OTE portal)	XP54	EUR	Settlement of DM – amount for positive energy - supply at a negative price (spot orders, OTE portal)	
953, 963	{1}	XC55	MWH	Settlement of DM - negative energy - consumption at a negative price (FS order)	XP55	EUR	Settlement of DM - amount for negative energy - consumption at a negative price (FS order)	
953, 963	{1}	XC56	MWH	Settlement of DM - positive energy - supply at a negative price (FS order)	XP56	EUR	Settlement of DM - amount for positive energy- supply at a negative price (FS order)	
953,963	{1}	XC57	MWH	Settlement of DM (cumulative PXE trades) - negative energy - consumption at a negative price (FS order)	XP57	EUR	Settlement of DM (cumulative PXE trades) - amount for negative energy - consumption at a negative price (FS order)	
953, 963	{1}	XC58	MWH	Settlement of DM (cumulative PXE trades) - positive energy - supply at a negative price (FS order)	XP58	EUR	Settlement of DM (cumulative PXE trades) - amount for negative energy - supply at a negative price (FS order)	
953, 963	{1}	XC59	MWH	Settlement of DM (cumulative PXE trades) - negative energy - consumption at a negative price (spot orders)	XP59	EUR	Settlement of DM (cumulative PXE trades) - amount for negative energy - consumption at a negative price (spot orders)	
953, 963	{1}	XC60	MWH	Settlement of DM (cumulative PXE trades) - positive energy - supply at a negative price (spot orders)	XP60	EUR	Settlement of DM (cumulative PXE trades) - amount for positive energy - supply at a negative price (spot orders)	
953, 963	{1}	XC61	MWH	Settlement of DM - negative energy - consumption at a negative price (spot orders, portal PXE)	XP61	EUR	Settlement of DM - amount for negative energy - consumption at a negative price (spot orders, portal PXE)	

2026 OTE, a.s.

Date of revision:
25.05.2026Document name:
D1.4.4_EN_Format_messages_XML_DM-IDA-Sol-RRD-FS-CDS.docx



Usage in message	Assignment profile to settlement version	Quantity ⁷⁵			Amount			Note
		Profile	Unit	Profile description	Profile	Unit	Profile description	
*/message-code	*/version	*/profile-role	*/unit		*/profile-role	*/unit		
953, 963	{1}	XC62	MWH	Settlement of DM - positive energy – supply at a negative price (spot orders, portal PXE)	XP62	EUR	Settlement of DM - amount for positive energy- supply at a negative price (spot orders, portal PXE)	
953, 963	{3, 4}	XC65	-	REMIT monthly fee - variable fee for orders electricity - number of orders	XP65	CZK	REMIT monthly fee - variable fee for electricity orders – negative amount for the number of orders	Currently not calculated XC65 profile unit: */unit="-" (dash) Period resolution: */resolution="P1M"
953, 963	{3, 4}	XC66	-	REMIT monthly fee - variable transaction fee electricity - number of transactions	XP66	CZK	REMIT monthly fee - variable fee for electricity transactions - negative amount for the number of transactions	Currently not calculated XC66 profile unit: */unit="-" (dash) Period resolution: */resolution="P1M"
953, 963	{2, 4, 5}	XC67	MWH	Emergency state IM export	XP67	CZK	Emergency state IM – amount for export	+/- (amount)
953, 963	{2, 4, 5}	XC68	MWH	Emergency state IM import	XP68	CZK	Emergency state IM – amount for import	+/- (amount)
953, 963	{2, 4, 5}	XC69	MWH	Emergency state DM export	XP69	CZK	Emergency state DM – amount for export	+/- (amount)
953, 963	{2, 4, 5}	XC70	MWH	Emergency state DM import	XP70	CZK	Emergency state DM – amount for import	+/- (amount)
953, 963	{2, 3, 4}	XC71	MWH	Quantity of BE- provided on TERRE at a negative BE- price	XP71	CZK	Amount for BE- provided on TERRE for negative price BE- (receivable)	
953, 963	{2, 3, 4}	XC72	MWH	Quantity of BE- provided on TERRE at positive/zero price BE-	XP72	CZK	Amount for BE- provided on TERRE for positive/zero price BE- (payable)	
953, 963	{2, 3, 4}	XC73	MWH	Quantity of BE+ provided on TERRE for a positive/zero BE+ price	XP73	CZK	Amount for BE+ provided on TERRE for positive/zero price BE+ (receivable)	
953, 963	{2, 3, 4}	XC74	MWH	Quantity of BE+ provided on TERRE at a negative BE+ price	XP74	CZK	Amount for BE+ provided on TERRE at a negative BE+ price (payable)	

2026 OTE, a.s.

Date of revision:
25.05.2026Document name:
D1.4.4_EN_Format_messages_XML_DM-IDA-Sol-RRD-FS-CDS.docx



Usage in message	Assignment profile to settlement version	Quantity ⁷⁵			Amount			Note
		Profile	Unit	Profile description	Profile	Unit	Profile description	
*/message-code	*/version	*/profile-role	*/unit		*/profile-role	*/unit		
963	{6, 15}	XC75	MWH	LP evaluation (distribution area EG.D) – negative energy	XP75	CZK	LP evaluation (distribution area EG.D) - negative amount for negative energy (payable)	
963	{6, 15}	XC76	MWH	LP evaluation (distribution area EG.D) – positive energy	XP76	CZK	LP evaluation (distribution area EG.D) – positive amount for positive energy (receivable)	
963	{6, 15}	XC77	MWH	LP evaluation (distribution area PRE Distribuce) – negative energy	XP77	CZK	LP evaluation (distribution area PRE Distribuce) - negative amount for negative energy (payable)	
963	{6, 15}	XC78	MWH	LP evaluation (distribution area PRE Distribuce) – positive energy	XP78	CZK	LP evaluation (distribution area PRE Distribuce) – positive amount for positive energy(receivable)	
963	{6, 15}	XC79	MWH	LP evaluation (distribution area ČEZ Distribuce) – negative energy	XP79	CZK	LP evaluation (distribution area ČEZ Distribuce) - negative amount for negative energy (payable)	
963	{6, 15}	XC80	MWH	LP evaluation (distribution area ČEZ Distribuce) – positive energy	XP80	CZK	LP evaluation (distribution area CEZ Distribuce) - positive amount for positive energy(receivable)	
953, 963	{2, 3, 4}	XC81	MWH	Quantity of BE+ provided at MARI (planned activation) at a positive/zero BE+ price	XP81	CZK	Amount for BE+ provided on MARI (planned activation) at positive/zero BE+ price (receivable)	
953, 963	{2, 3, 4}	XC82	MWH	Quantity of BE+ provided at MARI (planned activation) at a negative BE+ price	XP82	CZK	Amount for BE+ provided on MARI (scheduled activation) at a negative BE+ price (payable)	
953, 963	{2, 3, 4}	XC83	MWH	Quantity BE- provided on PICASSO at a negative price BE-	XP83	CZK	Amount for BE- provided on PICASSO at negative price BE- (receivable)	
953, 963	{2, 3, 4}	XC84	MWH	Quantity BE- provided on PICASSO at positive/zero price BE-	XP84	CZK	Amount for BE- provided on PICASSO at positive/zero price BE- (payable)	

2026 OTE, a.s.

Date of revision:
25.05.2026Document name:
D1.4.4_EN_Format_messages_XML_DM-IDA-Sol-RRD-FS-CDS.docx



Usage in message	Assignment profile to settlement version	Quantity ⁷⁵			Amount			Note
		Profile	Unit	Profile description	Profile	Unit	Profile description	
*/message-code	*/version	*/profile-role	*/unit		*/profile-role	*/unit		
953, 963	{2, 3, 4}	XC85	MWH	Quantity of BE+ provided on PICASSO for a positive/zero BE+ price	XP85	CZK	Amount for BE+ provided on PICASSO for positive/zero price BE+ (receivable)	
953, 963	{2, 3, 4}	XC86	MWH	Quantity of BE+ provided on PICASSO at a negative BE+ price	XP86	CZK	Amount for BE+ provided on PICASSO at a negative BE+ price (payable)	
953, 963	{2, 3, 4}	XC88	MWH	Quantity of BE- provided at MARI (direct activation) at a negative price of BE-	XP88	CZK	Amount for BE- provided on MARI (direct activation) at a negative BE-price (receivable)	
953, 963	{2, 3, 4}	XC89	MWH	Quantity of BE- provided at MARI (direct activation) at a positive/zero BE- price	XP89	CZK	Amount for BE- provided on MARI (direct activation) at positive/zero price BE- (payable)	
953, 963	{2, 3, 4}	XC90	MWH	Quantity of BE+ provided on MARI (direct activation) at a positive/zero BE+ price	XP90	CZK	Amount for BE+ provided on MARI (direct activation) at positive/zero BE+ price (receivable)	
953, 963	{2, 3, 4}	XC91	MWH	Quantity of BE+ provided at MARI (direct activation) at a negative BE+ price	XP91	CZK	Amount for BE+ provided on MARI (direct activation) at a negative BE+ price (payable)	
953, 963	{2, 3, 4}	XC92	MWH	Quantity of BE- provided at MARI (planned activation) at a negative price of BE-	XP92	CZK	Amount for BE- provisioned on MARI (planned activation) at a negative BE price - (receivable)	
953, 963	{2, 3, 4}	XC93	MWH	Quantity of BE- provided at MARI (planned activation) at a positive/zero BE- price	XP93	CZK	Amount for BE- provided on MARI (planned activation) for positive/zero BE price - (payable)	

7.3.3. Statistical data of settlement of imbalances

List of used profiles in the message Statistical data of settlement of imbalances (message-code = 966):

- The prices, amounts and quantities indicated in individual profiles can take on positive and negative values depending on the type of profile. Information about what value is returned in the profile is given in the Note column.

2026 OTE, a.s.

Date of revision:
25.05.2026

Document name:
D1.4.4_EN_Format_messages_XML_DM-IDA-Sol-RRD-FS-CDS.docx



Table 50 - Profile list – Statistical data of settlement of imbalances

Usage in message	Assignment profile to settlement version	Quantity ⁷⁶			Price/Amount ⁷⁷			Note
		Profile	Unit	Profile description	Profile	Unit	Profile description	
*/message-code	*/version	*/profile-role	*/unit		*/profile-role	*/unit		
966	{2; 3; 4}	SC02	MWH	Imbalance – positive energy	n/a	n/a		+(energy)
966	{2; 3; 4}	SC03	MWH	Imbalance – negative energy	n/a	n/a		-(energy)
966	{2; 3; 4}	SC13	MWH	System imbalance	n/a	n/a		+/(energy)
966	{2; 3; 4}	n/a	n/a		SP14	CZK	Costs of RE	+/(amount)
966	{2; 3; 4}	SC15	MWH	Costs of RE+ - quantity	SP15	CZK	Costs of RE + - amount	+(energy), +/(amount)
966	{2; 3; 4}	SC16	MWH	Costs of RE - - quantity	SP16	CZK	Costs of RE - - amount	-(energy), +/(amount)
966	{2; 3; 4}	n/a	n/a		SP50	CZK/MWH	Settlement price	+/(price)
966	{2; 3; 4}	n/a	n/a		SP51	CZK/MWH	Counter-imbalance settlement price	+/(price)
966	{2; 3; 4}	SC55	MWH	Rounding off imbalances	n/a	n/a		+/(energy)
966	{2; 3; 4}	XC87	-	Origin of the settlement price	n/a	n/a		The entire value indicating the method of determining the Settlement Price. Enumeration of return values: -1 – Component BE – Minimal price BE 1 – Component NE – Maximal price RE 2 – Component SO (settlement price curve) 3 – Component IM – Weighted average of prices of trades on IM 4 – Protective component BE – Weighted average of BE cost prices 5 – Price in state of emergency prevention

⁷⁶ n/a= Corresponding quantity profile to price/amount profile is not defined

⁷⁷ n/a= Corresponding price/amount profile to the quantity profile is not defined

2026 OTE, a.s.

Date of revision:
25.05.2026

Document name:
D1.4.4_EN_Format_messages_XML_DM-IDA-Sol-RRD-FS-CDS.docx



Usage in message	Assignment profile to settlement version	Quantity ⁷⁶			Price/Amount ⁷⁷			Note
		Profile	Unit	Profile description	Profile	Unit	Profile description	
*/message-code	*/version	*/profile-role	*/unit		*/profile-role	*/unit		
								XC87 profile unit: */unit="-" (dash)

7.3.4. Settlement results (gas)

List of used profiles in the report Results of accounting - gas (message-code = GFS):

- Amounts and quantities indicated in individual profiles can take on positive or negative values depending on the type of profile. Information about what value is returned in the profile is described either in the Profile Description itself or this information is specified in more detail in the Note column.

Table 51 - Profile list – Settlement results (gas)

Usage in message	Assignment profile to settlement version	Quantity ⁷⁸			Price			Note
		Profile	Unit	Profile description	Profile	Unit	Profile description	
*/message-code	*/version	*/profile-role	*/unit		*/profile-role	*/unit		
GSF	{13}	SC33	MWH	Settlement of IM with gas (consumption) – negative energy	SP33	EUR	Settlement of IM with gas (consumption) – amount for negative energy (payable)	-(energy), -(price)
GSF	{13}	SC34	MWH	Settlement of IM with gas (supply) – positive energy	SP34	EUR	Settlement of IM with gas (supply) – amount for positive energy(receivable)	+(energy), +(price)

⁷⁸ n/a = Corresponding quantity profile to price/amount profile is not defined



Usage in message	Assignment profile to settlement version	Quantity ⁷⁸			Price			Note
		Profile	Unit	Profile description	Profile	Unit	Profile description	
*/message-code	*/version	*/profile-role	*/unit		*/profile-role	*/unit		
GSF	{13}	SC35	MWH	IM fee with gas– total energy traded	SP35	CZK	IM fee with gas– negative amount for traded energy (payable)	
GSF	{11; 12}	n/a	n/a		ST14	CZK	Monthly fee for providing real values with gas - negative amount (payable)	Period resolution: */resolution="P1M"
GSF	{11; 12}	n/a	n/a		ST13	CZK	Monthly SS fee for settlement of imbalances with gas – negative amount (payable)	Period resolution: */resolution="P1M"
GSF	{11; 12}	n/a	n/a		ST19	CZK	Monthly fee REMIT – fixed fee gas – negative amount (payable)	Period resolution: */resolution="P1M"
GSF	{11; 12}	XC63	-	Monthly fee REMIT - variable fee for orders gas - number of orders	XP63	CZK	Monthly fee REMIT - variable fee for orders gas - negative amount for the number of orders (payable)	Currently not calculated XC63 profile unit: */unit="-" (dash) Period resolution: */resolution="P1M"
GSF	{11; 12}	XC64	-	REMIT monthly fee – variable transaction fee gas – number of transactions	XP64	CZK	Monthly fee REMIT – variable gas transaction fee – negative amount per transaction count (payable)	Currently not calculated XC63 profile unit: */unit="-" (dash) Period resolution: */resolution="P1M"

8. FS

8.1. Communication scenarios

All FS communication scenarios are always asynchronous. Based on the request for data in the format SFVOTREQ for the commodity electricity or SFVOTGASREQ for gas, the resulting report is generated and a technical response is returned in the format RESPONSE, or GAS RESPONSE.

A specific scenario common to both commodities is the question of the financial limit and its setting. Messages in the SFVOTREQ and SFVOTSETTINGS structures for the query and RESPONSE for the response are used.

The selected reports are automatically sent after the settlement without asking for data.

Table 52 - FS reports and their codes for the electricity commodity

Report name	Structure	Request code	Code of data	Response code
Invoicing documents	SFVOTBILLING	400	401	402
OTE Invoicing documents	SFVOTBILLING	403	404	405
Overview of payments and claims	SFVOTCLAIM	406	407	408
OTE Overview of payments and claims	SFVOTCLAIM	409	410	411
PXE – OTE Invoicing documents	SFVOTBILLINGEMO	418	419	420
OTE – PXE Invoicing documents	SFVOTBILLINGEMO	421	422	423
OTE settlement rate	SFVOTEXCHRATE	425	426	427
Claims and obligations	SFVOTDTEXPIMP	428	429	430
Confirmation	SFVOTCONFDATA	431	432	433
Invoicing documents– MI summary	SFVOTBILLINGSUM	434	435	436
OTE Invoicing documents – summary MI	SFVOTBILLINGSUM	437	438	439
Overview of payments and claims– summary FMI	SFVOTCLAIMSUM	440	441	442
OTE Overview of payments and claims– summary FMI	SFVOTCLAIMSUM	443	444	445
Monthly netting LP	SFVOTTDDNETT	460	461	462
Financial limit status	SFVOTLIMITS	463	464	465
Definitive netting LP	SFVOTTDDNETT	466	467	468
Definitive settlement of differences from LP	SFVOTTDD	469	470	471
Definitive settlement of differences from LP OTE	SFVOTTDD	472	473	474
RE Invoicing documents	SFVOTPSK	475	476	477
RE Overview of payments and claims	SFVOTPSK	478	479	480
CR Emergency state	SFVOTEMGSTATE	487	488	489
Emergency state – settlement of export/import from DM	SFVOTEMGSTATE	490	491	492
Emergency state – settlement of export/import from IDM	SFVOTEMGSTATE	493	494	495
Emergency state version 1 – netting	SFVOTEMGSTATENETT	496	497	498
Emergency state version 2 – netting	SFVOTEMGSTATENETT	499	500	501
Emergency state – paid payments OTE	SFVOTEMGSTATEINV	502	503	504
Predicted values of subject	CDSDATA	671	672	673

Table 53 - FS reports and their codes for the gas commodity

Report name	Structure	Request code	Code of data	Response code
--------------------	------------------	---------------------	---------------------	----------------------

Invoicing documents	SFVOTGASBILLING	GF1	GF2	GF3
OTE Invoicing documents	SFVOTGASBILLING	GF4	GF5	GF6
Overview of payments and claims	SFVOTGASCLAIM	GF7	GF8	GF9
OTE Overview of payments and claims	SFVOTGASCLAIM	GFA	GFB	GFC
Monthly settlement of differences from LP	SFVOTGASTDD	GFD	GFE	GFF
Monthly settlement of differences from LP OTE	SFVOTGASTDD	GFG	GFH	GFI
Invoicing documents– summary MI	SFVOTGASBILLINGSUM	GGK	GGM	GFL
OTE Invoicing documents – summary MI	SFVOTGASBILLINGSUM	GGN	GGQ	GFO
Complaints overview – summary FMI	SFVOTGASCLAIMSUM	GFP	GFQ	GFR
Complaints overview OTE – summary FMI	SFVOTGASCLAIMSUM	GFS	GST	GFU
LP Monthly netting	SFVOTGASTDDNETT	GFV	GFW	GFY
Definitive settlement of differences from LP	SFVOTGASTDD	GG5	GG6	GG7
Definitive settlement of differences from LP OTE	SFVOTGASTDD	GG8	GG9	GGA
OTE settlement rate – gas	SFVOTGASEXCHRATE	GGB	GGC	GGD
Invoicing documents– netting	SFVOTGASIMGNETT	GGE	GGF	GGG
Final monthly evaluation – netting	SFVOTGASIMGNETT	GGH	GGI	GGJ

Table 54 - FS reports and their codes for both commodities

Report name	Structure	Request code	Code of data	Response code
Financial limit status	SFVOTLIMITS	463	464	465
Current financial limit status for intraday markets	SFVOTLIMITS	481	482	483
Automatic change of IDM limit for electricity or IDM for gas	SFVOTLIMITCHANGE	-	484	485

8.2. Content of data messages

8.2.1. SFVOTREQ

This is a request for a report for the electricity commodity or an inquiry about the status of the financial limit for both commodities.

Table 55 - SFVOTREQ

Element/Attribute	Description
SFVOTREQ@message-code	Message code in this case identifying the report, see Above
SFVOTREQ/Interval@date-from	beginning of the period for the report
SFVOTREQ/Interval@date-to	end of reporting period

8.2.2. SFVOTGASREQ

This is a request for a report for the gas commodity. The meaning of the elements and attributes is the same as in the case of FVOTREQ , only the name of the root element is different.

8.2.3. SFVOTSETTINGS

This is a request to change the limit for intraday trading.

Table 56 - SFVOTSETTINGS

Element/Attribute	Description
SFVOTSETTINGS@message-code	message code 481
SFVOTSETTINGS/Setting/Limit@type	limit type – IME (electricity), IMG (gas)

SFVOTSETTINGS/Setting/Limit@value	new value in CZK
-----------------------------------	------------------

8.2.4. CDSDATA

Please see chapter 9.1.1 Description of changes in the existing CDSDATA format for changes.

8.2.5. RESPONSE

Description of the success of processing the request in the electricity commodity.

Table 57 - RESPONSE return codes for FS area

Code	Description	Returns data	Note
9000	OK	Yes	Reason does not contain any text. XML with data can be empty!
9001	No data found.	No	Reason does not contain text
9002	The request for data is not valid XML.	No	There is a description of the error in Reason
9003	Reporting module error.	No	Reason does not contain text
9004	Another financial module error.	No	Reason does not contain text
9005	NOTICE: A STATE OF EMERGENCY has been declared in the selected period. Daily settlement values are not valid for invoicing.	Yes	Reason does not contain text
9006	The subject is not authorized for the report type	No	Some reports are prepared only for a selected list of participants (e.g. Documents for PXE - OTE invoicing, Receivables and payables). This error is then returned if another participant requests this report.

8.2.6. GASRESPONSE

This is the result of processing in the commodity gas. The meaning of elements and attributes is the same as in the case of RESPONSE, only the name of the root element is different.

8.2.7. Data structures

All items of other data structures that are used in the FS module and listed in the tables [Table 52](#), [Table 53](#) and [Table 54](#) they are documented directly in the XSD definition using the relevant annotations.

9. CDS

9.1. CDSDATA message

9.1.1. Description of changes in the existing CDSDATA format

In connection with the change in the length of the settlement period to 15 minutes, the CDSDATA report will be modified.

From the point of view of changes, the "Location" part with subordinate segments containing its own measured data, which is the "Data" part, is decisive. The "Location" element contains the identification of the type of data being sent, and the "Data" element then contains the data itself.

Items that will be deleted (or items moved to another level) are visually represented with red crossed-out text, new items (or items moved from another level) are highlighted with green underlining.

Changes in the "Data" element

The data element contains the following attributes, the individual changes are listed in the table below.

Table 58 - Changes in the Data element

Attribute	Description	Marked changes
date-time-from	Start of measurement period	The time is now given in 15-minute intervals.
date-time-to	End of measurement period	The attribute is no longer included in the Data element.
qty	Quantity	Change in the number of decimal places. Newly, for example, the consumption value of continuous measurement will be given in kWh with accuracy to two decimal places.
unit	Unit	The attribute is no longer included in the Data element. The "Unit" attribute is moved to the "Location" element
status	Value status	The status of the value is not reported in the message if it is a valid value.

Example of the new look of the "Data" element (including a different status of the value):

```
<Data date-time-from="2020-05-13T00:00:00" qty="-458.75"/>
<Data date-time-from="2020-05-13T00:15:00" qty="-457.70"/>
<Data date-time-from="2020-05-13T00:30:00" qty="-499.00" status="99" />
<Data date-time-from="2020-05-13T00:45:00" qty="-430.10"/>
```

Changes in "Location" element

The existing attributes in the "Location" element are unchanged. However, the following attributes listed in the table have been added to the "Location" element.

Table 59 - Changes in the Location element

Attribute	Description	Marked changes
unit	Unit	The "Unit" attribute has been moved from the "Data" element. Contains the unit related to the quantity in the "Data" elements.

resolution	Period resolution	New attribute that determines the length of the period ("PT15M" - 15 min period, "PT60M" - 60 min period),
------------	-------------------	--

A sample of the element's new „Location“ form:

```
<Location id="859182400000000001" profile-role="A12" unit="KWH"
resolution="PT15M">
```

Example of changes to the CDSDATA message

```
<CDSDATA xmlns="http://www.ote-cr.cz/schema/cds/data"
xmlns:xsd="http://www.w3.org/2001/XMLSchema"
xmlns:xsi="http://www.w3.org/2001/XMLSchema-instance" answer-required="1"
date-time="2020-05-22T05:29:03" dtd-release="1" dtd-version="1"
id="M15000000000000000001" message-code="121" time-offset="2">
<SenderIdentification coding-scheme="14" id="8591820000000" />
<ReceiverIdentification coding-scheme="14" id="8591824000007" />
<Location id="859182400000000001" profile-role="A12" unit="KWH"
resolution="PT15M">
<Data date-time-from="2020-05-13T00:00:00" qty="-7.25"/>
<Data date-time-from="2020-05-13T00:15:00" qty="-8.30"/>
<Data date-time-from="2020-05-13T00:30:00" qty="-9.25"/>
<Data date-time-from="2020-05-13T00:45:00" qty="-8.25"/>
<Data date-time-from="2020-05-13T01:00:00" qty="-10.40" status="99"/>
<Data date-time-from="2020-05-13T01:15:00" qty="-11.25"/>
<Data date-time-from="2020-05-13T01:30:00" qty="-9.25"/>
...
...
...
<Data date-time-from="2020-05-13T23:00:00" qty="-8.25"/>
<Data date-time-from="2020-05-13T23:15:00" qty="-9.75"/>
<Data date-time-from="2020-05-13T23:30:00" qty="-11.20"/>
<Data date-time-from="2020-05-13T23:45:00" qty="-13.80"/>
</Location>
</CDSDATA>
```

9.1.2. Impact of changes to code lists

Distinction of the content and resolution of the communicated data will be carried out using a combination of profile role (attribute `profile-role`) and period resolution (attribute `resolution`).

Role of Profiles

The existing profile role code will be retained.

Data in a resolution of 15 minutes and 1 hour will be sent by the same profile role according to the content of the transmitted data.

Table 60 – Role of Profiles

Role	Types	No. of roles
Axxx	Measurements and aggregation continuous	53
Bxxx	Metered non-interval values	3

Cxxx	Negotiated profile	16
Exxx	Negotiated diagram	18
Fxxx	RE energy	140
Gxxx	RE price	140
Hxxx	Imbalance	8
Ixxx	Normalized LP	2
Jxxx	Corrected LP and correction coefficients	13
Kxxx	Climate conditions	4
Pxxx	Prediction	9
Sxxx	Sum corr./non-corr. estimates	144
Txxx	RE from trading platforms	296
SPxx		
SVxx		
DPxx		
DVxx		
PPxx		
PVxx		
EPxx		
EVxx		

For RE profiles from trading platforms (TERRE, MARI, PICASSO, GCC), the meaning of the profiles will change. The profile number will be reduced by discarding the third character of the profile role (period specification). The exact list and specification of profile roles for the 15-minute period will be published during the first half of 2024.

Time period resolution - attribute Resolution

The resolution of the length of the time period will be done using a new attribute `resolution`.

Table 61 – Time period resolution

Resolution	Description
PT15M	Period in 15 minute resolution
PT60M	Period in 60 minute resolution (for profile data before the day of the billing period change)

CDSDATA format message codes – Message-code attribute

Existing message codes will be used for sending messages with profile data (attribute `message-code` in the message header of the element CDSDATA).

Table 62 – Message codes with value profile

Message code	Message Meaning
121	Actual data from type A and B measurements
122	Actual data from type C measurements

124	RE activation data
125	Planned estimate of annual consumption for PDT with type C metering
160	Planned diagrams for consumption side (B)
161	Planned diagrams for the production side (A, B)
162	Planned values for factories with non-continuous measurement
232	Actual data for invoicing the merchant's partners
236	Actual data on the provided regulation energy
238	Planned estimate of annual consumption per PDT with non-continuous measurement
252	Negotiated diagrams for the management of responsibility for imbalances
266	Planned diagrams for the production side (A, B)
272	Query for replacement values - found data
303	Clearing - consumption estimation
313	Clearing - imbalances for PDT type C
316	ORS values entering the imbalance and clearing calculation
323	Clearing - metered values
333	Calculation per primary supplier of PDT
343	Aggregated values per supplier/customer
563	Estimated consumption diagrams of groups of PDT(C) - non-adjusted
603	History diagrams of correction factor of residual balance IS
613	Estimated consumption diagrams of groups of PDT(C) - adjusted
623	Metered data per IS - structured by A,B,C
633	Data to query data within the state of emergency
643	The actual data for suppliers divided into A, B, C
653	The actual data for suppliers and grid divided into A, B, C
656	Proportional aggregated ASC2 profile data by supplier
663	Data of normal and metered climatic conditions (temperatures)
666	Data of LP diagrams - output data
669	Temperature correction coefficient - output data
676	LP corr. to temperature and rest bil./LP

Data request messages will be retained and the data time period will be used to construct the data description message based on the period for which the data is being sent. That is, for dates before D-day 60 minutes, for dates from D-day onwards 15 minutes.

9.1.3. Documentation of the CDSDATA report in its entirety

Full documentation of the optimized CDSDATA report for sending continuous measurement data in 15 minutes / 60 minutes resolution. In attached document:



CDSDATA_15min.doc
c

2026 OTE, a.s.

Date of revision:
25.05.2026

Document name:
D1.4.4_EN_Format_messages_XML_DM-IDA-Sol-RRR-FS-CDS.docx